

▶▶▶ Thru-the-tool Coolant Available

▶▶▶ Thru-the-groove Coolant Available(Optional)

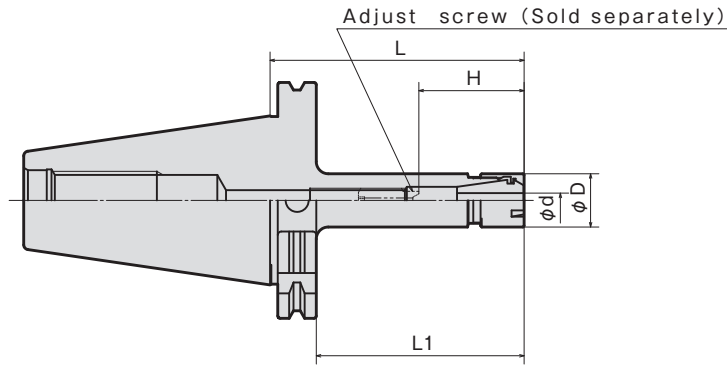

MODEL	CODE	ød	øD	L	L1	H	COLLET	NUT	ADJUST SCREW
SK30	SSC07-090	0.5~7	16	90	71	25~40	CR07-d	ER11MN	M6×20L-CTW
	SSC07-135			135	116				
	SSC10-090	0.5~10	22	90	71	31~48	CR10-d	ER16MN	RAS10-25-2.5
	SSC10-135			135	116				
	SSC13-090	0.5~13	28	90	71	35~52	CR13-d	ER20MN	RAS13-25-2.5
	SSC13-135			135	116				
SK40	SSC07-090	0.5~7	16	90	71	25~40	CR07-d	ER11MN	M6×20L-CTW
	SSC07-135			135	116				
	SSC10-090	0.5~10	22	90	71	31~48	CR10-d	ER16MN	RAS10-25-2.5
	SSC10-135			135	116				
	SSC13-105	0.5~13	28	105	86	35~52	CR13-d	ER20MN	RAS13-25-2.5
	SSC13-150			150	131				
SK50	SSC07-090	0.5~7	16	90	71	25~40	CR07-d	ER11MN	M6×20L-CTW
	SSC07-135			135	116				
	SSC10-105	0.5~10	22	105	86	31~48	CR10-d	ER16MN	RAS10-25-2.5
	SSC10-150			150	131				
	SSC13-120	0.5~13	28	120	101	35~52	CR13-d	ER20MN	RAS13-25-2.5
	SSC13-165			165	146				
SSC13-195			195	176					

NOTE : 1. Collet and chuck wrench are sold separately.
2. CROH collet is used for thru-the-tool coolant application.

ORDERING EXAMPLE			
①	②	③	④
SK50	- SSC	10	- 105
① Shank Size	② Holder's Name	③ Max. øD	④ G.L. Length

ACCESSORIES
➔ P.57 NUT

ACCESSORIES
➔ P.53-56 COLLETS

ACCESSORIES
➔ P.57 ADJUST SCREW, CHUCK WRENCH



CR COLLET

CR^{NO.}-D

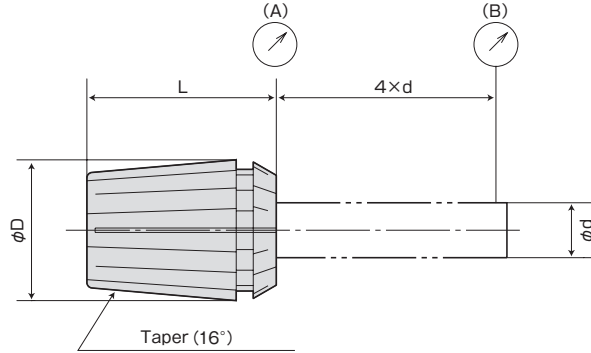

Easy collet setting

- A half of ID of the ring is enlarged. Collet can be mounted easily by inclining it.

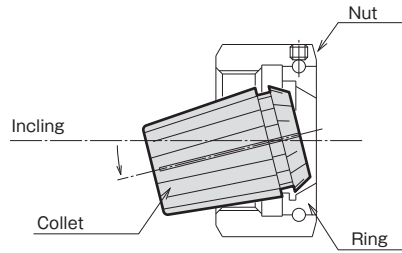

GRADE	RUNOUT (MAX. μm)	
	NOSE (A)	POINT (B)
(AA)	1	3
(A)	2	5
(STD)	5	15

Grade	application
AA grade · A grade	Reamer · Center drill Carbide small diameter drill, Endmill Whetstone for internal cylindrical grinding, Tool for high frequency motors Carbide drill Rotating tool for lathes (the tool rotation)
Standard	General drill, tap Rotating tool for lathes (Work rotating)

CHUCK COLLET CODE	RSC07		RSC10		RSC13		RSC16		RSC20	
	CR07-d	GRADE	CR10-d	GRADE	CR13-d	GRADE	CR16-d	GRADE	CR20-d	GRADE
φd	φd	RANGE	φd	RANGE	φd	RANGE	φd	RANGE	φd	RANGE
	1.0	0.5~1.0	1.0	0.5~1.0	1.0	0.5~1.0	1.5	1.0~1.5	2.0	1.5~2.0
	1.5	1.0~1.5	1.5	1.0~1.5	1.5	1.0~1.5	2.0	1.5~2.0	2.5	2.0~2.5
	2.0	1.5~2.0	2.0	1.5~2.0	2.0	1.5~2.0	2.5	2.0~2.5	3.0	2.5~3.0
	2.5	2.0~2.5	2.5	2.0~2.5	2.5	2.0~2.5	3.0	2.5~3.0	4.0	3.0~4.0
	3.0	2.5~3.0	3.0	2.5~3.0	3.0	2.5~3.0	4.0	3.0~4.0	5.0	4.0~5.0
	3.5	3.0~3.5	4.0	3.0~4.0	4.0	3.0~4.0	5.0	4.0~5.0	6.0	5.0~6.0
	4.0	3.5~4.0	5.0	4.0~5.0	5.0	4.0~5.0	6.0	5.0~6.0	7.0	6.0~7.0
	4.5	4.0~4.5	6.0	5.0~6.0	6.0	5.0~6.0	7.0	6.0~7.0	8.0	7.0~8.0
	5.0	4.5~5.0	7.0	6.0~7.0	7.0	6.0~7.0	8.0	7.0~8.0	9.0	8.0~9.0
	5.5	5.0~5.5	8.0	7.0~8.0	8.0	7.0~8.0	9.0	8.0~9.0	10.0	9.0~10.0
	6.0	5.5~6.0	9.0	8.0~9.0	9.0	8.0~9.0	10.0	9.0~10.0	11.0	10.0~11.0
	6.5	6.0~6.5	10.0	9.0~10.0	10.0	9.0~10.0	11.0	10.0~11.0	12.0	11.0~12.0
	7.0	6.5~7.0			11.0	10.0~11.0	12.0	11.0~12.0	13.0	12.0~13.0
					12.0	11.0~12.0	13.0	12.0~13.0	14.0	13.0~14.0
					13.0	12.0~13.0	14.0	13.0~14.0	15.0	14.0~15.0
						15.0	14.0~15.0	16.0	15.0~16.0	
						16.0	15.0~16.0	17.0	16.0~17.0	
								18.0	17.0~18.0	
								19.0	18.0~19.0	
								20.0	19.0~20.0	
φD	11		16		20		25		32	
L	18		27		31		35		40	

Collet for through the groove (produce by order) are also available.

ORDERING EXAMPLE

① CR07 - ② 1.5 ③ AA

- ① Chuck Type
- ② φd
- ③ Grade

ACCESSORIES for COLLET CHUCK



OIL HOLE CR COLLET

CROH[®]-D

FEATURES

- For thru-the-tool coolant application.
- High pressure up to 7 Mpa is acceptable.
- Standard holders and nuts can be used.
- Bearing of nut is not affected by coolant.

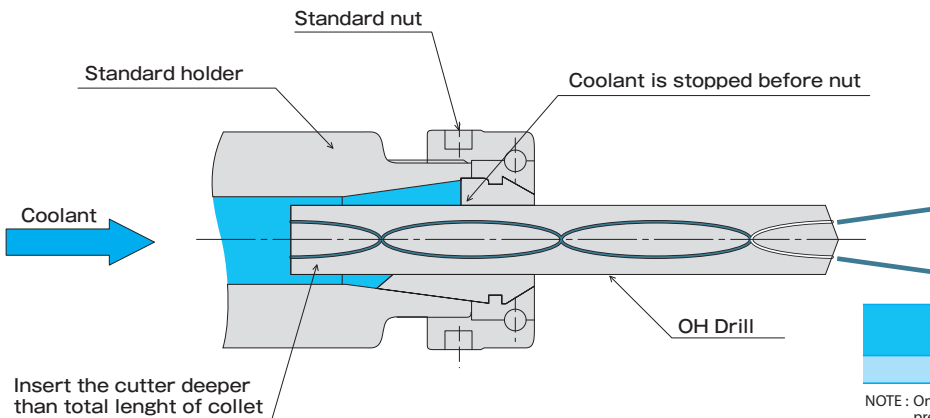

GRADE	RUNOUT (MAX. μm) 4 \times d
(AA)	5 μm

NOTE : Only super precious grade (AA) is available for sale only ultra precision grade (AA) type.

COLLET CODE/CHUCK	RSC07 CROH07-d GRADE		RSC10 CROH10-d GRADE		RSC13 CROH13-d GRADE		RSC16 CROH16-d GRADE		RSC20 CROH20-d GRADE	
ϕd	ϕd	RANGE	ϕd	RANGE	ϕd	RANGE	ϕd	RANGE	ϕd	RANGE
	2.0	1.9~2.0	2.0	1.9~2.0	3.0	2.9~3.0	3.0	2.9~3.0	3.0	2.9~3.0
	2.5	2.4~2.5	2.5	2.4~2.5	3.5	3.4~3.5	3.5	3.4~3.5	3.5	3.4~3.5
	3.0	2.9~3.0	3.0	2.9~3.0	4.0	3.9~4.0	4.0	3.9~4.0	4.0	3.9~4.0
	4.0	3.9~4.0	4.0	3.9~4.0	4.5	4.4~4.5	4.5	4.4~4.5	4.5	4.4~4.5
	4.5	4.4~4.5	4.5	4.4~4.5	5.0	4.9~5.0	5.0	4.9~5.0	5.0	4.9~5.0
	5.0	4.9~5.0	5.0	4.9~5.0	5.5	5.0~5.5	5.5	5.4~5.5	5.5	5.4~5.5
	5.5	5.4~5.5	5.5	5.0~5.5	6.0	5.5~6.0	6.0	5.5~6.0	6.0	5.9~6.0
	6.0	5.9~6.0	6.0	5.5~6.0	6.5	6.0~6.5	6.5	6.0~6.5	6.5	6.4~6.5
	6.5	6.4~6.5	6.5	6.0~6.5	7.0	6.5~7.0	7.0	6.5~7.0	7.0	6.9~7.0
	7.0	6.9~7.0	7.0	6.5~7.0	7.5	7.0~7.5	7.5	7.0~7.5	7.5	7.4~7.5
			7.5	7.0~7.5	8.0	7.5~8.0	8.0	7.5~8.0	8.0	7.5~8.0
			8.0	7.5~8.0	8.5	8.0~8.5	8.5	8.0~8.5	8.5	8.0~8.5
			8.5	8.0~8.5	9.0	8.5~9.0	9.0	8.5~9.0	9.0	8.5~9.0
			9.0	8.5~9.0	9.5	9.0~9.5	9.5	9.0~9.5	9.5	9.0~9.5
			9.5	9.0~9.5	10.0	9.5~10.0	10.0	9.5~10.0	10.0	9.5~10.0
			10.0	9.5~10.0	10.5	10.0~10.5	10.5	10.0~10.5	10.5	10.0~10.5
					11.0	10.5~11.0	11.0	10.5~11.0	11.0	10.5~11.0
					11.5	11.0~11.5	11.5	11.0~11.5	11.5	11.0~11.5
					12.0	11.5~12.0	12.0	11.5~12.0	12.0	11.5~12.0
					12.5	12.0~12.5	12.5	12.0~12.5	12.5	12.0~12.5
					13.0	12.5~13.0	13.0	12.5~13.0	13.0	12.5~13.0
							13.5	13.0~13.5	13.5	13.0~13.5
							14.0	13.5~14.0	14.0	13.5~14.0
							14.5	14.0~14.5	14.5	14.0~14.5
							15.0	14.5~15.0	15.0	14.5~15.0
							15.5	15.0~15.5	15.5	15.0~15.5
							16.0	15.5~16.0	16.0	15.5~16.0
								16.5	16.0~16.5	
								17.0	16.5~17.0	
								17.5	17.0~17.5	
								18.0	17.5~18.0	
								18.5	18.0~18.5	
								19.0	18.5~19.0	
								19.5	19.0~19.5	
								20.0	19.5~20.0	
ϕD		11		16		20		25		32
L		18		27		31		35		40

- NOTE : 1. Applicable for drill with oil hole.
 2. When in use insert a drill to the end from the rear of the collet.
 3. Do not use smaller sized cutting tools than inner diameter of collet, or coolant may leak out of a collet.
 4. If flat-face shank cutting tool is used, sealing function of collet does not work.

ORDERING EXAMPLE

① CROH10 - ② 10 ③ AA

① Chuck Type
 ② ϕd
 ③ Grade



CR TAP COLLET

CR[®]GB-[⊖]

CR collet with square hole for shank end of tap (for synchro tap).

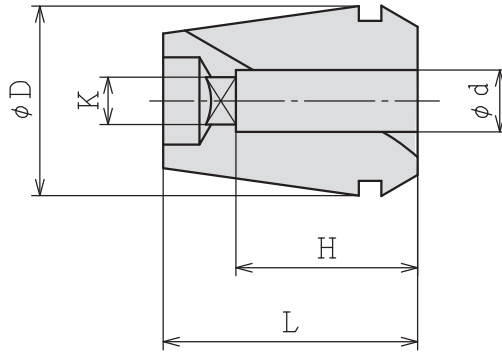

MODEL	CODE	TAP SIZE	ϕd	K	H	ϕD	L	TAP HOLDER	COLLET CHUCK
CR10GB	-M4	84700	M4	5	4	16	27	-	RSC10
	-M5	84702	M5	5.5	4.5				
	-M6	84704	M6	6	4.5				
	-M8	84706	M8	6.2	5				
	-M10	84708	M10	7	5.5				
	-P1/8	84710	P1/8	8	6				
CR13GB	-M4	84712	M4	5	4	20	31	SYFN12	RSC13
	-M5	84714	M5	5.5	4.5				
	-M6	84716	M6	6	4.5				
	-M8	84718	M8	6.2	5				
	-M10	84720	M10	7	5.5				
	-P1/8	84722	P1/8	8	6				
	-M12	84724	M12	8.5	6.5				
CR16GB	-M4	84726	M4	5	4	25	35	SYFN16S	RSC16
	-M5	84728	M5	5.5	4.5				
	-M6	84730	M6	6	4.5				
	-M8	84732	M8	6.2	5				
	-M10	84734	M10	7	5.5				
	-P1/8	84736	P1/8	8	6				
	-M12	84738	M12	8.5	6.5				
	-M14	84740	M14	10.5	8				
	-P1/4	84742	P1/4	11	9				
	-M16	84744	M16	12.5	10				
	-P3/8	84746	P3/8	14	11				
CR20GB	-M4	84748	M4	5	4	32	40	SYFN20	RSC20
	-M5	84750	M5	5.5	4.5				
	-M6	84752	M6	6	4.5				
	-M8	84754	M8	6.2	5				
	-M10	84756	M10	7	5.5				
	-P1/8	84758	P1/8	8	6				
	-M12	84760	M12	8.5	6.5				
	-M14	84762	M14	10.5	8				
	-P1/4	84764	P1/4	11	9				
	-M16	84766	M16	12.5	10				
	-P3/8	84768	P3/8	14	11				
	-M18	84770	M18	14	11				
	-M20	84772	M20	15	12				

NOTE : 1. Above table is for a tap of JIS standard shank.
2. Run-out accuracy is subject to ordinary (STD) class.

ACCESSORIES for COLLET CHUCK



OIL HOLE CR TAP COLLET

CR¹⁰GH-[⊕]

OH-type collet with square hole is for high-pressure centre-through coolant feeding (for synchro tapping) .

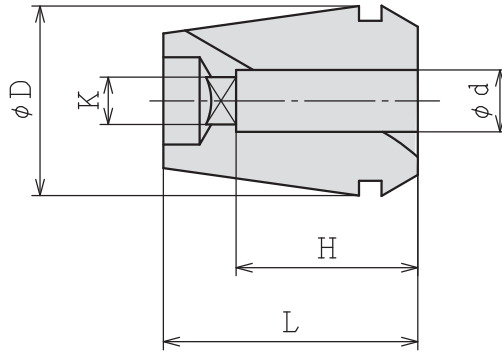

MODEL	CODE	TAP SIZE	ϕd	K	H	ϕD	L	TAP HOLDER	COLLET CHUCK
CR10GH	-M6	84800	M6	6	4.5	16	27	-	RSC10
	-M8	84802	M8	6.2	5				
	-M10	84804	M10	7	5.5				
	-P1/8	84806	P1/8	8	6				
CR13GH	-M6	84808	M6	6	4.5	20	31	SYFN12	RSC13
	-M8	84810	M8	6.2	5				
	-M10	84812	M10	7	5.5				
	-P1/8	84814	P1/8	8	6				
CR16GH	-M6	84818	M6	6	4.5	25	35	SYFN16S	RSC16
	-M8	84820	M8	6.2	5				
	-M10	84822	M10	7	5.5				
	-P1/8	84824	P1/8	8	6				
	-M12	84826	M12	8.5	6.5				
	-M14	84828	M14	10.5	8				
	-P1/4	84830	P1/4	11	9				
CR20GH	-M6	84836	M6	6	4.5	32	40	SYFN20	RSC20
	-M8	84838	M8	6.2	5				
	-M10	84840	M10	7	5.5				
	-P1/8	84842	P1/8	8	6				
	-M12	84844	M12	8.5	6.5				
	-M14	84846	M14	10.5	8				
	-P1/4	84848	P1/4	11	9				
	-M16	84850	M16	12.5	10				
	-P3/8	84852	P3/8	14	11				
	-M18	84854	M18	14	11				
-M20	84856	M20	15	12					

- NOTE :
- Above table is for a tap of JIS standard shank.
 - Run-out accuracy is subject to ordinary (STD) class.
 - In the case of OSG Corporation synchro tap, shank diameter, square end dimensions are different from others so that there is the case that you can not use it even if tap size is the same.
 - Gap-through collet is also available. Please order separately.

ACCESSORIES for COLLET CHUCK



NUT FOR COLLET CHUCK

RSN (No.) - TYPE

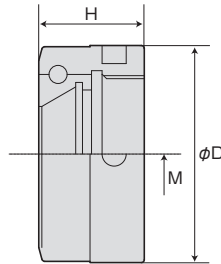

for BT, ST

Through-Coolant use

CODE	M	φD	H	CHUCK
RSN07NB (Ni) 30891	M16×1.0	24	11.5	RSC07
RSN10NB (Ni) 30892	M21×1.0	30	15.5	RSC10
RSN13NB (Ni) 30893	M26×1.0	36	17.5	RSC13
RSN16NB (Ni) 30894	M32×1.0	42	17.5	RSC16
RSN20NB (Ni) 30895	M40×1.0	50	17.5	RSC20

CODE	M	φD	H	CHUCK
RSN10NB-OH 30870	M21×1.0	30	15.5	RSC10
RSN13NB-OH 30871	M26×1.0	36		RSC13
RSN16NB-OH 30872	M32×1.0	42	17.5	RSC16
RSN20NB-OH 30873	M40×1.0	50		RSC20

Note: Single use of OH nut can not cope with the thru-the-tool coolant.



ADJUST SCREW (For COLLET CHUCK)

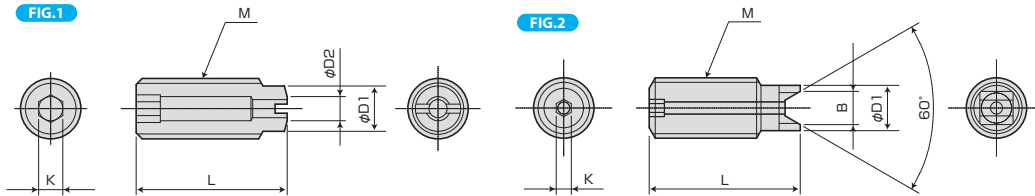

MODEL	FIG	M	L	D1	D2	K	B	HOLDER
M6×20L-CTW 1)	1	M6×1.0	20	4.5	3	3	—	RSC07
RAS10-25-2.5 2)	2	M10×1.5	25	7.5	—	2.5	5.5	RSC10
RAS13-25-2.5 2)		M12×1.5		9.5			7.2	RSC13
RAS16-25-5 2)		M18×1.5		13.5			9.5	RSC16
RAS20-25-5 2)		M24×1.5		17.5			—	RSC20

Note 1: Drill less than φ3 cannot be used for adjustment protrusion in order to enter the coolant hole.

CTW is not in the two pieces shape

Note 2: Drill less than φ2 cannot be used for adjustment protrusion in order to enter the coolant hole.



CHUCK WRENCH (For COLLET CHUCK)

CODE	CHUCK
FP25 35844	RSC07
FP30 35845	RSC10
FP35 35846	RSC13
FP42 35847	RSC16
FP50 35848	RSC20