

BT
シリーズ

オイルホールハードチャック

BT[®](No.)-OH-CTH[®](D)-L

OIL-HOLE HARD CHUCK

BT series

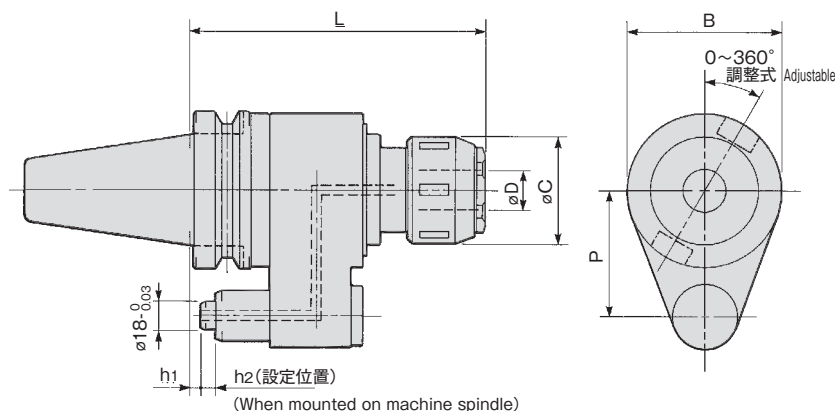

使用条件 CUTTING CONDITIONS	
最高回転数 MAX.RPM	3000min ⁻¹
最高切削油圧 MAX.COOLANT PRESSURE	2.0MPa

	MODEL	CODE	øD	øC	L	B	P
BT50	-OH-CTH16-170	13851	16	52	170	98	80
	-CTH25-185	13852	25	68	185	98	
	-CTH32-195	13854	32	83	195	120	

注：h1、h2は各メーカー及び機種により異なりますので、御注文頂きます際には、メーカー及び機種を御連絡願います。

NOTE: When ordering, please inform h1 and h2 dimensions, which differ depending on machine maker and model.

アクセサリ ACCESSORIES
P.50 コレット COLLETS

アクセサリ ACCESSORIES
P.52 チャックレンチ CHUCK WRENCH

ご注文例 ORDERING EXAMPLE

① BT50 ② OH-CTH ③ 16 ④ 170

① シャンクサイズ Shank Size
② 呼称 Name
③ 刃具シャンク径 øD Cutter's Shank Dia.
④ GL長さ L G.L. Length

ハードチャック用アクセサリ

ACCESSORIES for HARD CHUCK



スプリングコレット (ハードチャック用)

SPRING COLLET (For HARD CHUCK)

C(No) - (D)

ご注文例 ORDERING EXAMPLE

① C16 - ② 6

① チャック本体 Chuck Type
② øD øD

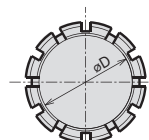
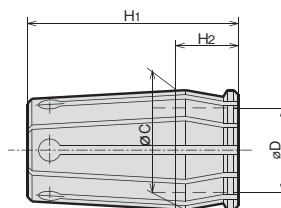

CODE	øD										øC	H1	H2	適用ホルダ			
	6	8	10	12	16	20	25	32	42	50				50.8	CTH12L	CTH	CT
C12L-D	6	8	10	12								18.00	40	13	CTH12L	—	—
C16-D	6	8	10	12	16							24.00	50	17	—	CTH16	—
C20-D	6	8	10	12	16	20						28.75	50	15	—	CTH20	—
C25-D			10	12	16	20	25					35.75	68	19	—	CTH25	CT25
C32-D					16	20	25	32				45.25	80	21	—	CTH32	CT32
※CS32-D(SHORT)					16	20	25	32				45.25	70	21	—	CTH32	—
C42-D						20	25	32	42			55.00	90	21	—	CTH42	—
C50-D								32	42	50	50.8	65.00	95	25	—	CTH50	—

注:※ CS32-D (SHORT) は、ハードチャックBT40・NT40用に使して下さい。 NOTE※ CS32-D(SHORT) spring collet is for BT40・NT40 Hard Chuck.

ハードチャック用アクセサリ

ACCESSORIES for HARD CHUCK



ノーズ (ハードチャック用)

NOSE PIECE (For HARD CHUCK)

N(No)-D

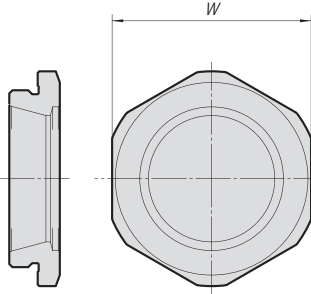

MODEL	CODE	W	適用ホルダ
N16-16	33702	39	CTH16
N20-20	33703	43	CTH20
N25-25	33704	51	CTH25
N32-32	33706	63	CTH32
N42-42	33708	74	CTH42
N50-50	33710	84	CTH50



防じんノーズ (ハードチャック用)

NOSE PIECE (For HARD CHUCK)

NG(No)-D

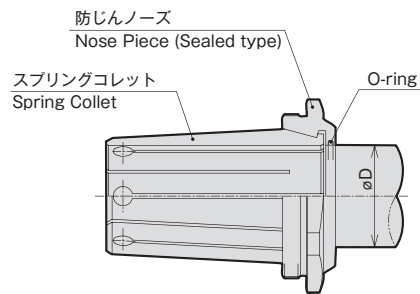

ご注文例 ORDERING EXAMPLE

① NG ② 16 ③ - 6

① 呼称	Name
② チャックサイズ	Chuck Size
③ øD	øD

CODE	øD										HARD CHUCK CODE	
NG16-øD	6	8	10	12	16							CTH16
NG20-øD	6	8	10	12	16	20						CTH20
NG25-øD				12	16	20	25					CTH25
NG32-øD					16	20	25	32				CTH32
NG42-øD						20	25	32	42			CTH42
NG50-øD								32	42	50	50.8	CTH50



チャックレンチ

CHUCK WRENCH



チャックコード ハードチャック HARD CHUCK	レンチコード WRENCH CODE	
CTH12L,CTH16	FK50-55	805224
CTH20,CT25G	FK58-65	805226
CTH25	FK65-70	805228
CT32G	FK70-75	805230
CTH32	FK80-85	805232
CTH42	FK92-100	805234
CTH50	FK105-115	805236

BT series

HSK series

ST series

Versatile Tool

Cutting Tool

Accessories

Data