

# オイルホールホルダ<sup>®</sup> (モールステーパ式)

BT (No.) -OH-MT (No.) -L

OIL-HOLE ADAPTER (Morse taper Type)

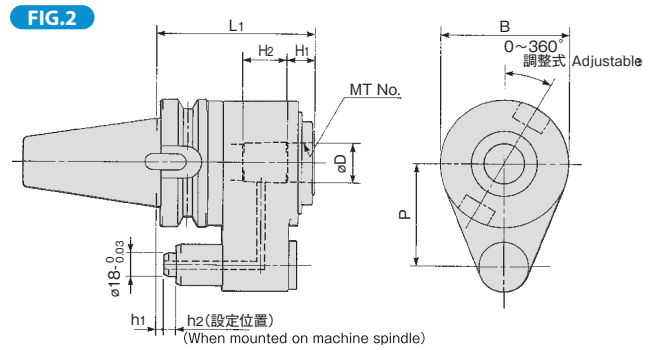
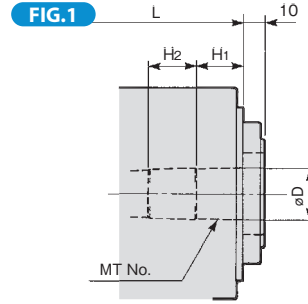

	MODEL	CODE	FIG.	MT No.	$\phi D$	L	H1	H2	B	P
BT40	-OH-MT3-105	11422	2	MT3	23.825	105	21	22	80	65
	-MT4-120	11424	2	MT4	31.267	120	21	34		
BT50	-OH-MT3-110	13832	1	MT3	23.825	110	21	22	98	80
	-MT4-120	13834	2	MT4	31.267	120	21	34		82
	-MT5-135	13836	2	MT5	44.399	135	40	45		85

注：h1、h2は各メーカー及び機種により異なりますので、御注文頂きます際には、メーカー及び機種を御連絡願います。

NOTE: When ordering, please inform h1 and h2 dimensions, which differ depending on machine maker and model.

### ご注文例 ORDERING EXAMPLE

① **BT40** ② **-OH-MT** ③ **3** ④ **-105**

- ① シャンクサイズ Shank Size
- ② 呼称 Name
- ③ MT No. MT No.
- ④ GL長さ L G.L. Length

# モールステーパスリーブ

OH-MT (No.) (A) - (B)

MT SLEEVE

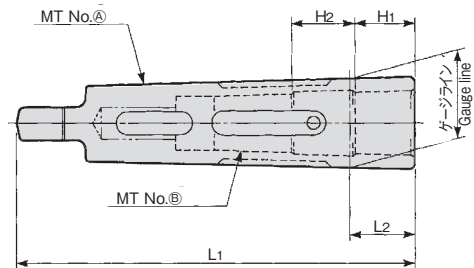

	CODE	MT No. (A)	MT No. (B)	L1	L2	H1	H2	N/W (kg)
	OH-MT4-3	17706	3	140	22.5	21	22	0.37
	OH-MT4-2	17704	2	124	6.5	17	20	0.42
	OH-MT3-2	17702	2	112	18	17	20	0.17

### ご注文例 ORDERING EXAMPLE

① **OH-MT** ② **4** ③ **-3**

- ① 呼称 Name
- ② MT No.A MT No.A
- ③ MT No.B MT No.B

BT series

HSK series

ST series

Versatile Tool

Cutting Tool

Accessories

Data