

| MODEL | CODE | øD(h6) | L | øC1 | H | KEY | | G1 | CLAMP BOLT | | | | N/W (kg) | | |
|------------|------------|--------|----|-----|-------|------|------|------|------------|-----|----|----|----------|-----|-----|
| | | | | | | W | K | | øC4 | øC5 | H3 | H4 | | | |
| HSKA50 | -SMA16-060 | 25610 | 60 | 34 | 17 | 7.95 | 3 | M 8 | 20 | 15 | 7 | 9 | 0.6 | | |
| | -120 | 25611 | | | | | | | | | | | 120 | 34 | 17 |
| | -SMA22-060 | 25620 | 60 | 42 | 27 | | 9.95 | 3.5 | M10 | 28 | 18 | 9 | 11 | 1.0 | |
| | -120 | 25621 | | | | | | | | | | | | 120 | 42 |
| | -SMA27-060 | 25630 | 60 | 50 | 36 | | | 9.95 | 4 | M12 | 33 | 23 | 10 | 12 | 1.3 |
| | -120 | 25631 | | | | | | | | | | | | | 120 |
| -SMA32-060 | 25640 | 60 | 60 | 38 | 9.95 | 4.5 | | | M16 | 40 | 23 | 10 | 16 | 1.7 | |
| -120 | 25641 | | | | | | | | | | | | | 120 | 60 |
| HSKA63 | -SMA16-060 | 26610 | 60 | 34 | | 17 | 7.95 | | 3 | M 8 | 20 | 15 | 7 | 9 | 0.8 |
| | -120 | 26611 | | | | | | | | | | | | | 120 |
| | -SMA22-060 | 26620 | 60 | 42 | | 27 | | 9.95 | 3.5 | M10 | 28 | 18 | 9 | 11 | 1.1 |
| | -120 | 26621 | | | | | | | | | | | | | 120 |
| | -SMA27-060 | 26630 | 60 | 50 | 36 | 9.95 | | | 4 | M12 | 33 | 23 | 10 | 12 | 1.4 |
| | -120 | 26631 | | | | | | | | | | | | | 120 |
| -SMA32-060 | 26640 | 60 | 60 | 38 | 9.95 | | 4.5 | | M16 | 40 | 23 | 10 | 16 | 1.8 | |
| -120 | 26641 | | | | | | | | | | | | | 120 | 60 |
| HSKA100 | -SMA22-060 | 27620 | 60 | 42 | | | 27 | 7.95 | 3.5 | M10 | 28 | 18 | 9 | 11 | 2.3 |
| | -120 | 27621 | | | | | | | | | | | | | 120 |
| | -SMA27-060 | 27630 | 60 | 50 | | 36 | 9.95 | | 4 | M12 | 33 | 23 | 10 | 12 | 2.8 |
| | -120 | 27631 | | | | | | | | | | | | | 120 |
| | -SMA32-060 | 27640 | 60 | 60 | 38 | 9.95 | | | 4.5 | M16 | 40 | 23 | 10 | 16 | 3.0 |
| | -120 | 27641 | | | | | | | | | | | | | 120 |
| -SMA40-060 | 27650 | 60 | 80 | 38 | 11.95 | | | 4.5 | M20 | 50 | 27 | 14 | 20 | 3.0 | |
| -120 | 27651 | | | | | | | | | | | | | 120 | 80 |

NOTE : 1. Coolant pipe is included.

| ORDERING EXAMPLE | | | |
|------------------|-------------|---|----------------|
| ① | HSKA50 | - | ② SMA 16 - 060 |
| ① | Shank Size | | |
| ② | Name | | |
| ③ | øD | | |
| ④ | G.L. Length | | |



CLAMP BOLT FOR FACE MILL ARBOR

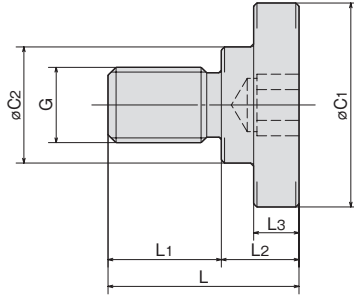

| MODEL | CODE | $\phi C1$ | $\phi C2$ | L | L1 | L2 | L3 | G | ARBOR CODE |
|-----------|-------|-----------|-----------|----|----|----|----|-----------|-------------------------------|
| MBA - M 8 | 49771 | 20 | 15 | 23 | 14 | 9 | 7 | M 8×P1.25 | FMA22.225 SMA16 |
| MBA - M10 | 49772 | 28 | 18 | 27 | 16 | 11 | 9 | M10×P1.5 | SMA22 SMB22.225 |
| MBA - M12 | 49773 | 33 | 23 | 30 | 18 | 12 | 10 | M12×P1.75 | FMA,B25.4 FMB27 SMA27 |
| MBA - M16 | 49774 | 40 | 23 | 40 | 24 | 16 | 10 | M16×P2.0 | FMA31.75 SMA32 SMB31.75 |
| MBA - M20 | 49775 | 50 | 27 | 50 | 30 | 20 | 14 | M20×P2.5 | FMA,B38.1 FMB40 SMA40 SMB38.1 |
| MBA - M24 | 49776 | 65 | 37 | 59 | 35 | 24 | 14 | M24×P3.0 | FMA50.8 |



< HSK SHANK > COOLANT PIPE

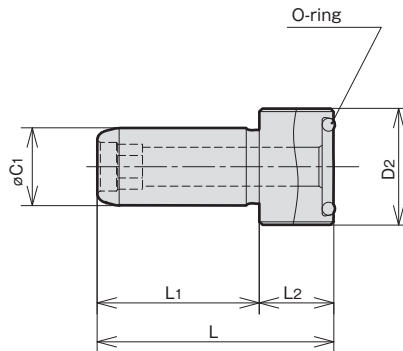

| MODEL | CODE | HSK No. | D1 | D2 | L | L1 | L2 | O-ring |
|---------|-------|---------|----|---------|------|------|------|--------|
| CLP-032 | 25180 | HSK32 | 6 | M10×1.0 | 26 | 20.5 | 5.5 | P4 |
| CLP-040 | 25181 | HSK40 | 8 | M12×1.0 | 29.5 | 22 | 7.5 | P6 |
| CLP-050 | 25182 | HSK50 | 10 | M16×1.0 | 33 | 23.5 | 9.5 | P9 |
| CLP-063 | 25183 | HSK63 | 12 | M18×1.0 | 36.5 | 25 | 11.5 | P11 |
| CLP-080 | 25184 | HSK80 | 14 | M20×1.5 | 40 | 26.5 | 13.5 | P12 |
| CLP-100 | 25185 | HSK100 | 16 | M24×1.5 | 44 | 28.5 | 15.5 | P15 |

ORDERING EXAMPLE

① **CLP** - ② **032**

- ① Name
- ② HSK No.