

FIG.1

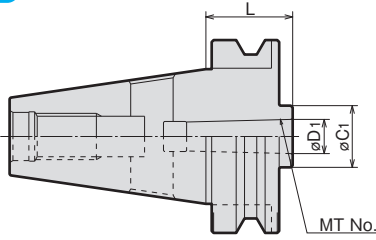
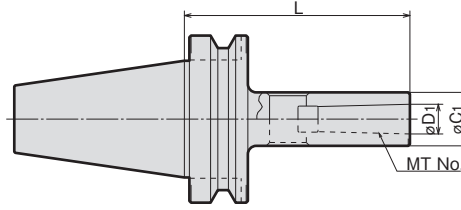

FIG.2



DRILL DIA. AND SHANK

SHANK	MT1	MT2	MT3	MT4	MT5
DRILL DIA. 以上MIN.	2.0	14.1	23.1	32.1	50.1
以下MAX.	14.0	23.0	32.0	50.0	75.0

MODEL	FIG.	MT No.	L	øD1	øC1	N/W (kg)
BT30 (BBT30)	-MTA1-045	1	45	12.065	25	0.43
	-MTA2-060	1	60	17.780	32	0.50
	-MTA3-080	1	3	80	23.825	40
BT40 (BBT40)	-MTA1-045	1	45	12.065	25	1.0
	-120		120			1.3
	-180		180			1.6
	-MTA2-045	2	45	17.780	25	1.0
	-120		120			1.6
	-180		180			2.0
	-MTA3-075	3	75	23.825	25	1.0
	-135		135			1.7
	-180		180			2.2
	-MTA4-090	4	90	31.267	25	1.1
	-165		165			2.6
	-200		200			3.5
BT50 (BBT50)	-MTA1-045	1	45	12.065	25	3.7
	-120		120			4.0
	-180		180			4.3
	-200		200			4.5
	-250		250			4.7
	-300		300			4.9
	-350		350			5.1
	-MTA2-045	2	45	17.780	25	3.7
	-135		135			4.3
	-180		180			4.6
	-200		200			4.7
	-250		250			5.1
	-300		300			5.5
	-350		350			5.9
	-MTA3-045	3	45	23.825	25	3.6
	-150		150			4.7
	-180		180			4.9
	-200		200			5.2
	-250		250			5.7
	-300		300			6.2
	-350		350			6.7

MODEL	FIG.	MT No.	L	øD1	øC1	N/W (kg)
BT50 (BBT50)	-MTA4-075	1	75	31.267	50	3.8
	-180	2	180			5.4
	-200		200			5.7
	-250		250			6.5
	-300		300			7.3
	-350		350			8.0
	-MTA5-105	1	105	44.399	65	4.0
	-210	2	210			6.7
	-250		250			7.8
	-300		300			9.1
	-350		350			10.4
	-MTA6-210		6	210	63.348	90
-278		278		10.0		

NOTE : 1. For tongue type Morse taper shank cutting tools.

ORDERING EXAMPLE			
①	BT30	-	MTA
②		-	1
③		-	045
④		-	
①	Shank Size		
②	Holder's Name		
③	MT No.		
④	G.L. Length		

## MORSE TAPER HOLDER (Type B)

BT<sup>①</sup>-MTB<sup>②</sup>-L

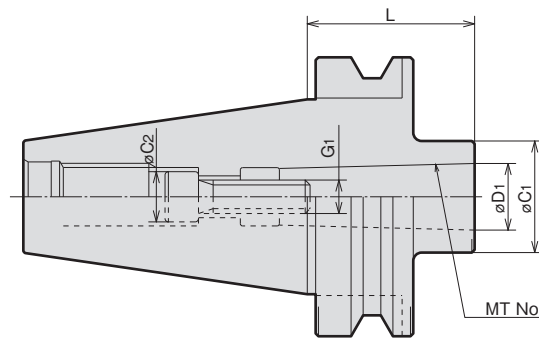

MODEL	CODE	MT No.	L	øD1	øC1	øC2	G1	N/W (kg)
BT40	-MTB1-045	11167	45	12.065	25	10	M6	1.0
	-MTB2-045	11168	45	17.780	32	14	M10	1.0
BT50	-MTB1-045	13332	45	12.065	25	10	M6	3.6
	-MTB2-045	13334	45	17.780	32	16	M10	3.6
	-MTB3-060	13336	60	23.825	40	18	M12	3.7
	-MTB4-075	13338	75	31.267	50	20.5	M16	3.7

NOTE : 1. For drawing thread type Morse taper shank cutting tools.

ORDERING EXAMPLE			
①	BT40	-	MTB
②		-	1
③		-	045
④		-	
①	Shank Size		
②	Holder's Name		
③	MT No.		
④	G.L. Length		