

SIDE LOCK DRILL HOLDER

BT^①-CSL^②D^③-L^④

▶▶▶ Thru-the-tool Coolant Available

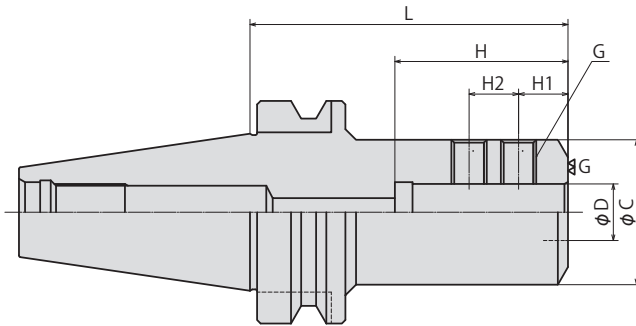

ORDERING EXAMPLE

① BT30 - ② CSL - ③ 16 - ④ 060

- ① Shank Size
- ② Holder's Name
- ③ Cutter's Shank Dia.
- ④ G.L. Length

MODEL	øD	L	øC	H	H1	H2	G	
BT30	CSL16-060	16	60	41	49	14	14	M10
	CSL20-060	20		45				
	CSL25-065	25		47				
BT40	CSL16-060	16	60	41	49	14	14	M10
	CSL16-090	90						
	CSL20-060	20						
	CSL20-090	20	90	45	51	14	14	M10
	CSL25-060	25	60	48	57	15	20	M12
	CSL25-090	25	90	48	57			
	CSL32-075	32	75	61	61			
	CSL32-105	32	105	68	71	15	25	M14
	CSL40-105	40	105					
CSL40-105	40	105						
BT50	CSL16-040	16	40	-	49	18	-	M12
	CSL16-105	105	41	49		14	14	M10
	CSL16-135	135						
	CSL16-165	165						
	CSL20-040	20	40	-	51	18	-	M12
	CSL20-105	105	45	51		14	14	M10
	CSL20-135	135						
	CSL20-165	165						
	CSL25-040	25	40	-	57	20	-	M16
	CSL25-105	105	48	57		15	20	M12
	CSL25-135	135						
	CSL25-165	165						
	CSL32-040	32	40	-	61	20	-	M16
	CSL32-105	105	61	61		15	20	M12
	CSL32-135	135						
	CSL32-165	165						
	CSL40-050	40	50	-	71	14	-	M14
	CSL40-105	105	68	71		15	25	
	CSL40-135	135						
	CSL40-165	165						
	CSL50-105	50	105	83	81			M16

NOTE:1.For endmill of straight shank with flat.