

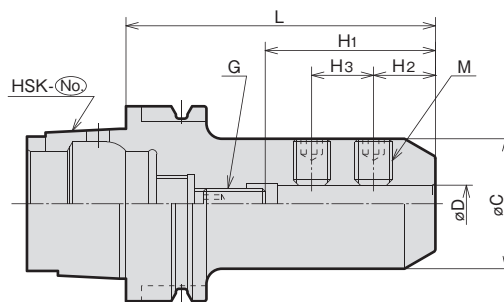

特長 FEATURES

- 偏芯構造により、振れ精度の向上。
- Run-out of the cutting tool is improved by the eccentric ID.



MODEL	CODE	$\phi D(H6)$	L	ϕC	H1		H2	H3	M	G	N/W (kg)	
					MIN.	MAX.						
HSKA50	-SLA06-075	25710	6	75	30	18	28	13	-	M 6	M 5	0.7
	-SLA08-080	25720	8	80	35	23	33	15		M 8	M 6	0.8
	-SLA10-090	25730	10	90	42	25	38	18	M10	M 8	0.9	
	-SLA12-100	25740	12	100	48	30	43	20	M12	M10	1.1	
	-SLA16-120	25750	16	120	50	35	50	24	M14	M12	1.7	
-SLA20-140	25760	20	140	50	55	70	25	M16	2.0			
HSKA63	-SLA06-075	26710	6	75	30	18	28	13	-	M 6	M 5	0.9
	-SLA08-080	26720	8	80	35	23	33	15		M 8	M 6	1.0
	-SLA10-090	26730	10	90	42	25	38	18		M10	M 8	1.1
	-SLA12-100	26740	12	100	48	30	43	20	M12	M10	1.3	
	-SLA16-100	26750	16	100	48	35	46	24	M14	M12	1.6	
	-SLA20-120	26760	20	120	50	55	65	25	M16		2.5	
	-SLA25-130	26770	25	130	61	55	70	24	25		M18	3.0
-SLA32-140	26780	32	140	72	65	75	24	28	M20	4.2		
HSKA100	-SLA06-085	27710	6	85	30	18	28	13	-	M 6	M 5	2.2
	-SLA08-090	27720	8	90	35	23	33	15		M 8	M 6	2.3
	-SLA10-100	27730	10	100	42	25	38	18		M10	M 8	2.4
	-SLA12-110	27740	12	110	48	30	43	20		M12	M10	2.6
	-SLA16-110	27750	16	110	48	35	50	24	M14	M12	2.9	
	-SLA20-130	27760	20	130	50	55	70	25	M16		3.8	
	-SLA25-140	27770	25	140	61	55	70	24	25		M18	4.5
	-SLA32-150	27780	32	150	72	65	80	24	28		M20	5.5

- 注：1. クーラントパイプは付属されております。(固定式)
2. フラット付ストレートシャンク刃具をご使用下さい。

NOTE: 1. Coolant pipe is included.
2. For endmill of straight shank with flat.

ご注文例 ORDERING EXAMPLE

①	HSKA50	-	②	SLA	③	06	-	④	075
①	シャンクサイズ		②	呼称				④	Holder's Name
			③	刃具シャンク径 ϕD					Cutter's Shank Dia.
			④	GL長さ L					G.L. Length