

サイドロックドリルホルダ

BT[®]-CSL[®]D-L

SIDE LOCK DRILL HOLDER

▶▶ センタースルー対応 Thru-the-tool Coolant Available

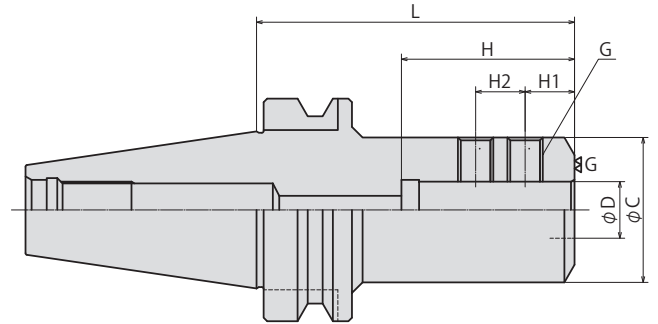

MODEL	CODE		φD	L	φC	H	H1	H2	G		
	BT	BBT									
BT30 BBT30	CSL16-060	10027	200594	16	60	41	49	14	14	M10	
	CSL20-060	10028	200596	20		45					
	CSL25-065	10029	200598	25		47					
BT40 BBT40	CSL16-060	11780	240630	16	60	41	49	14	14	M10	
	CSL16-090	11782	240632	90							
	CSL20-060	11784	240634	20	45						
	CSL20-090	11786	240636	90	48	57	15	20	M12×1.25		
	CSL25-060	11788	240638	25						60	
	CSL25-090	11790	240640	90							
	CSL32-075	11792	240642	32	75	61	61	25	M14×1.5		
	CSL32-105	11794	240644	105							
	CSL40-105	11796	240646	40	68						
BT50 BBT50	CSL16-040	13101	270670	16	40	41	49	18	14	14	M12×1.25
	CSL16-105	13102	270672		105						
	CSL16-135	13103	270674		135						
	CSL16-165	13104	270676		165						
	CSL20-040	13105	270678	20	40	45	51	18	14	14	M10
	CSL20-105	13106	270680		105						
	CSL20-135	13107	270682		135						
	CSL20-165	13108	270684		165						
	CSL25-040	13109	270686	25	40	48	57	20	15	20	M12
	CSL25-105	13110	270688		105						
	CSL25-135	13111	270690		135						
	CSL25-165	13112	270692		165						
	CSL32-040	13113	270694	32	40	61	61	20	15	20	M16×1.5
	CSL32-105	13114	270696		105						
	CSL32-135	13115	270698		135						
	CSL32-165	13116	270700		165						
	CSL40-050	13117	270702	40	50	68	71	14	15	25	M14×1.5
	CSL40-105	13118	270704		105						
	CSL40-135	13119	270706		135						
	CSL40-165	13120	270708		165						
CSL50-105	13121	270710	50	105	83	81					M16×1.5

注: 1. フラット付ストレートシャンク刃具をご使用ください。

2. BBTは受注生産品です。

NOTE: 1. For endmill of straight shank with flat.

2. BBT shank type is made-to-order.

ご注文例 ORDERING EXAMPLE

① BT30 - ② CSL - ③ 16 - ④ 060

① シャンクサイズ	Shank Size
② 呼称	Holder's Name
③ 刃具シャンク径 φD	Cutter's Shank Dia.
④ GL長さ L	G.L. Length

BT series

HSK series

ST series

Versatile Tool

Cutting Tool

Accessories

Data