

Data

技術資料

BTシャンク寸法表	171	BT SHANK DIMENSIONS
NTシャンク寸法表	171	NT SHANK DIMENSIONS (Manual Tool-Chage Type)
MTシャンク寸法表<タング付>	172	MORSE TAPER SHANK DIMENSIONS <Tongue Type>
SKMシャンク寸法表	172	SKM SHANK DIMENSIONS
HSKシャンク寸法表	173	HSK SHANK DIMENSIONS
クーラントパイプ寸法表	173	COOLANT PIPE DIMENSIONS
HSK各タイプの形状・特徴	174	VARIOUS FORMS OF HSK SHANKS AVAILABLE
硬度換算表	175	APPROXIMATE CONVERSION TO ROCKWELL C HARDNESS
国際単位換算表	176	INTERNATIONAL SYSTEM OF UNITS
常用するはめあいの軸で用いる寸法許容差	177,178	DIMENSIONAL TOLERANCE FOR SHAFTS IN COMMON FITS
常用するはめあいの穴で用いる寸法許容差	179,180	DIMENSIONAL TOLERANCE FOR HOLES IN COMMON FITS
タップ下穴表	181	DRILL DIAMETERS FOR TAPPING
六角穴付ボルトに対する座グリ・ボルト穴寸法表	181	DIMENSIONS OF COUNTERBORING FOR HEXAGON SOCKET HEAD CAP SCREW AND BOLT HOLE

BTシャンク寸法表

BT SHANK DIMENSIONS

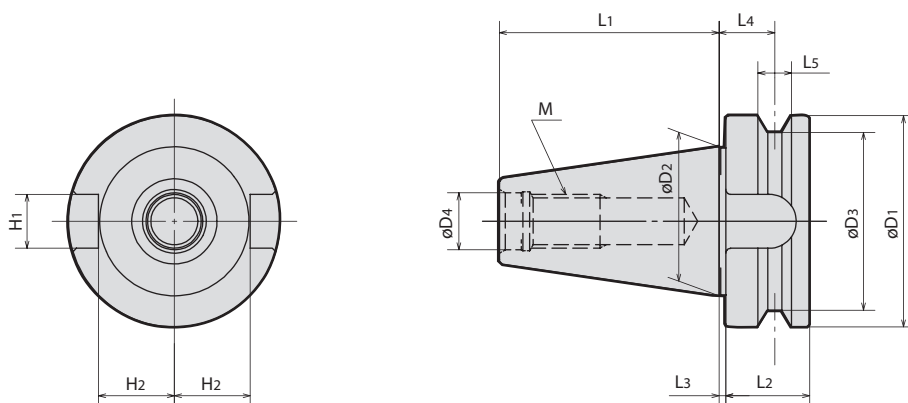

BTNo.	ϕD_1	ϕD_2	ϕD_3	ϕD_4	L1	L2	L3	L4	L5	H1	H2	M
BT30	46	31.75	38	12.5	48.4	20	2	13.6	8	16.1	16.3	M12
BT35	53	38.10	43		56.4	22		14.6	10		19.6	
BT40	63	44.45	53		65.4	25		16.6	10		22.6	
BT45	85	57.15	73	21	82.8	30	3	21.2	12	19.3	29.1	M20
BT50	100	69.85	85	25	101.8	35		23.2	15	25.7	35.4	M24
BT55	125	88.90	107	31	126.8	40		26.2	18		45.1	
BT60	155	107.95	135		161.8	45	28.2	20	60.1		M30	

NTシャンク寸法表

NT SHANK DIMENSIONS (Manual Tool-Chage Type)

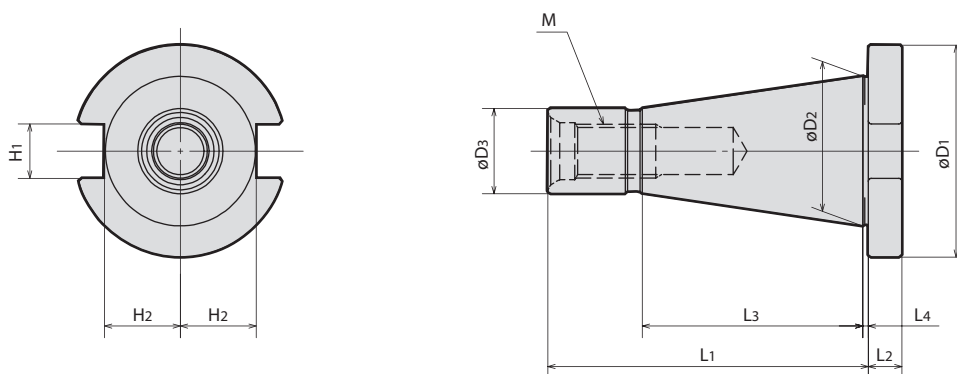

NTNo.	ϕD_1	ϕD_2	ϕD_3	L1	L2	L3	L4	H1	H2	M		
										メートルネジ Metric screw	ユニファイネジ Unified screw	ウィットネジ Whitworth screw
NT30	46	31.75	17.4	70	10	48.4	1.6	16.1	16.2	M12	1/2-13UNC	W1/2
NT40	63	44.45	25.3	95		65.4			22.5	M16	5/8-11UNC	W5/8
NT50	100	69.85	39.6	130	12	101.8	3.2	25.7	35.3	M24	1'-8UNC	W1'
NT60	155	107.95	60.2	210	15	161.8			60	M30	1 1/4-7UNC	W1 1/4

MTシャンク寸法表 <タング付>

MORSE TAPER SHANK DIMENSIONS <Tongue Type>

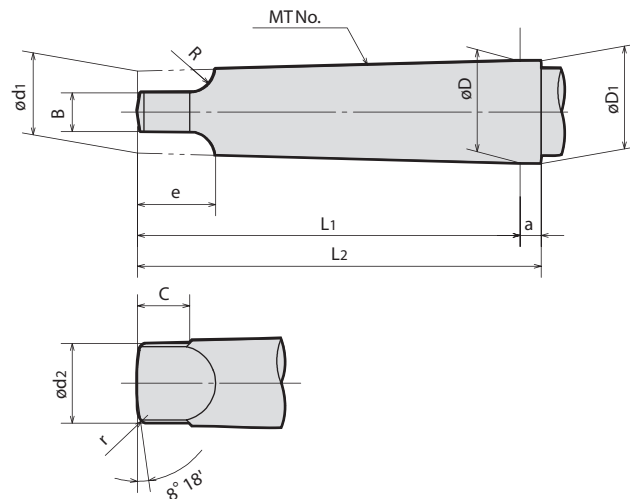

M.T. No.	øD	a	øD1	ød1	ød2 (Max.)	L1 (Max.)	L2 (Max.)	B	C	e (Max.)	R (Max.)	r
0	9.045	3	9.2	6.1	6	56.5	59.5	3.9	6.5	10.5	4	1
1	12.065	3.5	12.2	9	8.7	62	65.5	5.2	8.5	13.5	5	1.2
2	17.780	5	18.0	14	13.5	75	80	6.3	10	16	6	1.6
3	23.825		24.1	19.1	18.5	94	99	7.9	13	20	7	2
4	31.267	6.5	31.6	25.2	24.5	117.5	124	11.9	16	24	8	2.5
5	44.399		44.7	36.5	35.7	149.5	156	15.9	19	29	10	3
6	63.348	8	63.8	52.4	51	210	218	19	27	40	13	4

SKMシャンク寸法表

SKM SHANK DIMENSIONS

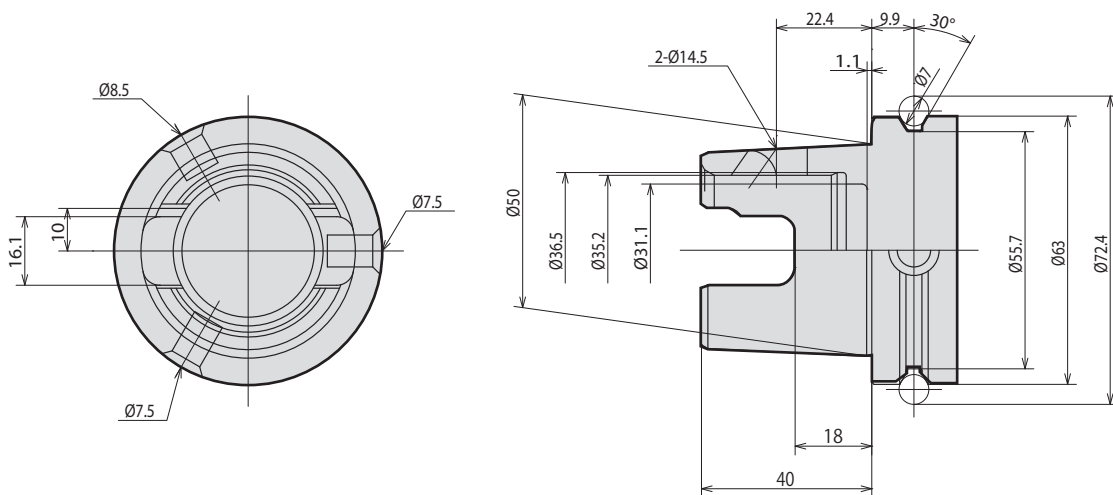

BT series

HSK series

ST series

Versatile Tool

Cutting Tool

Accessories

Data

HSKシャック寸法表

HSK SHANK DIMENSIONS

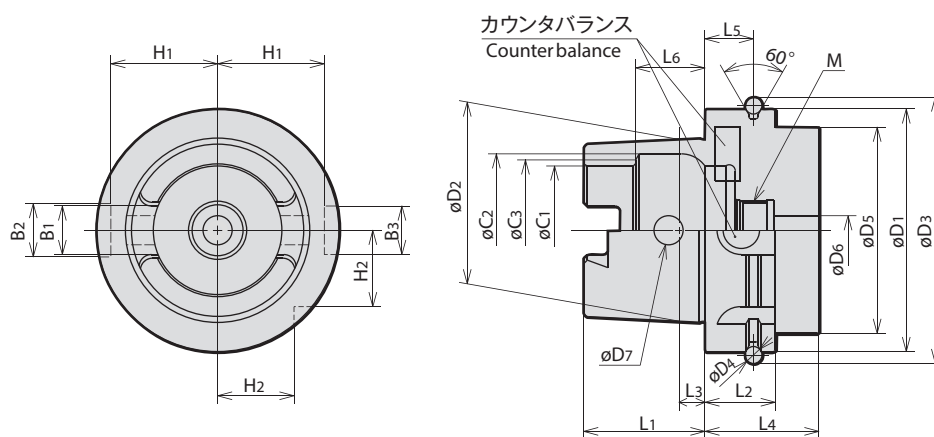

HSK No.	φD1	φD2	φD3	φD4	φD5 (Max.)	φD6 (Max.)	φD7	L1	L2	L3	L4 (Min.)	L5
HSKA 32	32	24	37	4	26	4.2	4	16	20	3.2	35	16
HSKA 40	40	30	45		34	5	4.6	20		4		
HSKA 50	50	38	59.3	7	42	6.8	6	25	26	5	42	18
HSKA 63	63	48	72.3		53	8.4	7.5	32		6.3		
HSKA 80	80	60	88.8		67	10.2	8.5	40		8		
HSKA100	100	75	109.75		85	12	12	50	10	29	45	20
HSKA125	125	95	134.75	105	14	—	63	12.5				
HSKA160	160	120	169.75	—	130	16	—	80	31	16	47	22

HSK No.	L6	φC1	φC2	φC3	B1	B2	B3	H1	H2	M
HSKA 32	8.92	17	21	19	7.05	9	7	13	9.5	M10×1.0
HSKA 40	11.42	21	25.5	23	8.05	11	9	17	12	M12×1.0
HSKA 50	14.13	26	32	29	10.54	14	12	21	15.5	M16×1.0
HSKA 63	18.13	34	40	37	12.54	18	16	26.5	20	M18×1.0
HSKA 80	22.85	42	50	46	16.04	20	18	34	25	M20×1.5
HSKA100	28.56	53	63	58	20.02	22	20	44	31.5	M24×1.5
HSKA125	36.27	67	80	73	25.02	28	25	55.5	39.5	M30×1.5
HSKA160	45.98	85	100	92	30.02	36	32	72	50	M35×1.5

クーラントパイプ (固定式) 寸法表

COOLANT PIPE DIMENSIONS

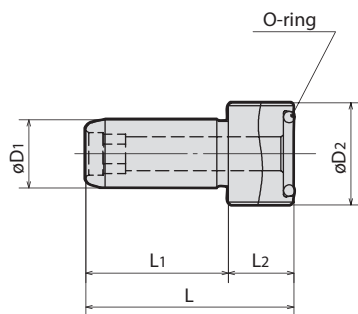

CODE	φD1	φD2	L	L1	L2	O-ring	HSK No.
CLP-032	6	M10×1.0	26	20.5	5.5	P4	HSK32
CLP-040	8	M12×1.0	29.5	22	7.5	P6	HSK40
CLP-050	10	M16×1.0	33	23.5	9.5	P9	HSK50
CLP-063	12	M18×1.0	36.5	25	11.5	P11	HSK63
CLP-080	14	M20×1.5	40	26.5	13.5	P12	HSK80
CLP-100	16	M24×1.5	44	28.5	15.5	P15	HSK100

HSK各タイプの形状・特徴

VARIOUS FORMS OF HSK SHANKS AVAILABLE

A 型 A type

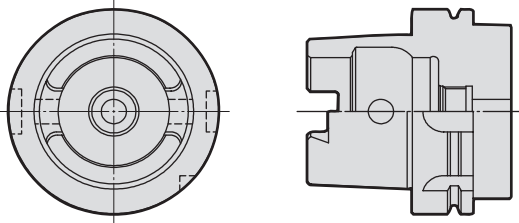

- 用途: マシニングセンタ
- クーラントパイプを使用して軸心給油可能
- テーパ部上端のドライブキー溝によるトルク伝達
- ATC用U溝
- マニュアルクランプ穴
- ジャーマンノッチ
- IDチップ穴(オプション)
- For machining centers.
- Through-the-tool coolant from coolant tube acceptable.
- With drive slots at the top of taper portion.
- With "U" slots for ATC.
- With pin holes for manual clamping.
- With a German notch.
- With a hole for ID chip. (Option)

B 型 B type

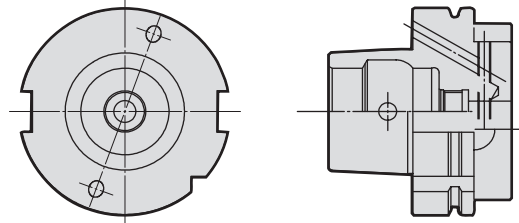

- 用途: マシニングセンタ・汎用フライス盤・旋盤
- フランジスルー給油またはクーラントパイプを使用して軸心給油可能
- フランジ部のU溝によるトルク伝達
- マニュアルクランプ穴
- ジャーマンノッチ
- IDチップ穴(オプション)
- 呼びシャックに対し、テーパ部は1サイズ小さくなります。
- For machining centers, milling machines and lathes.
- Through-the-tool coolant from flange or from coolant tube acceptable.
- With "U" drive slots at the flange.
- With pin holes for manual clamping.
- With a German notch.
- With a hole for ID chip. (Option)
- With one rank smaller taper size.

C 型 C type

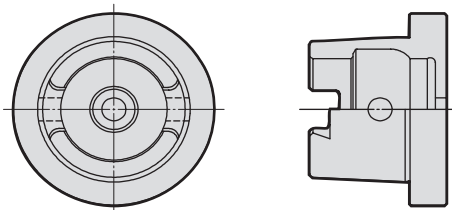

- 用途: トランスファマシンなどATC機能の無い専用機
- 軸心給油可能
- テーパ部のドライブキー溝によるトルク伝達
- For non-ATC machines, such as transfer machines.
- Through-the-tool coolant acceptable.
- With drive slots at the top of taper portion.

D 型 D type

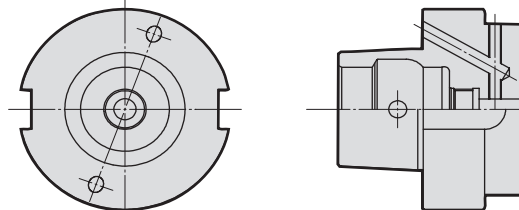

- 用途: トランスファマシンなどATC機能の無い専用機
- フランジスルー給油またはクーラントパイプを使用しての軸心給油可能
- フランジ部のU溝によるトルク伝達
- 呼びシャックに対し、テーパ部は1サイズ小さくなります。
- For non-ATC machines, such as transfer machines.
- Through-the-tool coolant from flange or from coolant tube acceptable.
- With "U" drive slots at the flange.
- With one rank smaller taper size.

E 型 E type

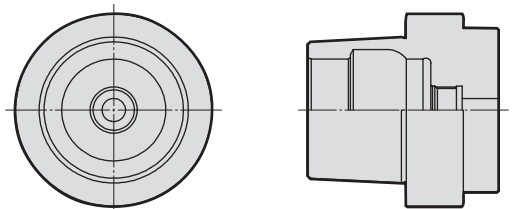

- 用途: 高速回転用マシニングセンタ、木工機械
- 対称型、ドライブキー溝無し
- 摩擦によるトルク伝達
- クーラントパイプを使用しての軸心給油可能
- For high speed machining centers and wood milling machines.
- With symmetrical shank without drive key slot.
- Friction transmission.
- Through-the-tool coolant from coolant tube acceptable.

F 型 F type

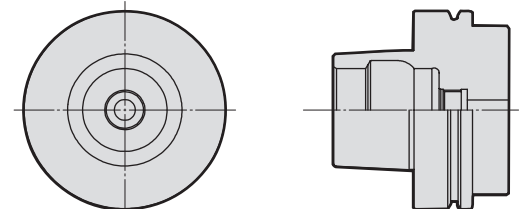

- クーラントパイプを使用しての軸心給油可能
- 呼びシャックに対し、テーパ部は1サイズ小さくなります。
- Through-the-tool coolant from coolant tube
- With one rank smaller taper size.

BT series

HSK series

ST series

Versatile Tool

Cutting Tool

Accessories

Data

硬度換算表

APPROXIMATE CONVERSION TO ROCKWELL C HARDNESS

ロックウェルCスケール硬さ Rockwell hardness C scale	ピッカース硬さ Vickers hardness	ブリネル硬さ 10mm球荷重 29.4kN Brinell hardness 10mm ball Load 29.4kN	ロックウェル硬さ Rockwell hardness		ショア硬さ Shore hardness	引張硬さ (近似値) Tension load (Approximate value)
			Aスケール A scale	Bスケール B scale		
HRC	HV	HB	HRA	HRB	HS	MPa
68	940	—	85.6	—	97	—
67	900	—	85.0	—	95	—
66	865	—	84.5	—	92	—
65	832	—	83.9	—	91	—
64	800	—	83.4	—	88	—
63	772	—	82.8	—	87	—
62	746	—	82.3	—	85	—
61	720	—	81.8	—	83	—
60	697	—	81.2	—	81	—
59	674	—	80.7	—	80	—
58	653	[615]	80.1	—	78	—
57	633	[595]	79.6	—	76	—
56	613	[577]	79.0	—	75	—
55	595	[560]	78.5	—	74	2075
54	577	[543]	78.0	—	72	2015
53	560	[525]	77.4	—	71	1950
52	544	[512]	76.8	—	69	1880
51	528	[496]	76.3	—	68	1820
50	513	[481]	75.9	—	67	1760
49	498	[469]	75.2	—	66	1695
48	484	451	74.7	—	64	1635
47	471	442	74.1	—	63	1580
46	458	432	73.6	—	62	1530
45	446	421	73.1	—	60	1480
44	434	409	72.5	—	58	1435
43	423	400	72.0	—	57	1385
42	412	390	71.5	—	56	1340
41	402	381	70.9	—	55	1295
40	392	371	70.4	—	54	1250
39	382	362	69.9	—	52	1215
38	372	353	69.4	—	51	1180
37	363	344	68.9	—	50	1160
36	354	336	68.4	(109.0)	49	1115
35	345	327	67.9	(108.5)	48	1080
34	336	319	67.4	(108.0)	47	1055
33	327	311	66.8	(107.5)	46	1025
32	318	301	66.3	(107.0)	44	1000
31	310	294	65.8	(106.0)	43	980
30	302	286	65.3	(105.5)	42	950
29	294	279	64.7	(104.5)	41	930
28	286	271	64.3	(104.0)	41	910
27	279	264	63.8	(103.0)	40	880
26	272	258	63.3	(102.5)	38	860
25	266	253	62.8	(101.5)	38	840
24	260	247	62.4	(101.0)	37	825
23	254	243	62.0	100.0	36	805
22	248	237	61.5	99.0	35	785
21	243	231	61.0	98.5	35	770
20	238	226	60.5	97.8	34	760
(18)	230	219	—	96.7	33	730
(16)	222	212	—	95.5	32	705
(14)	213	203	—	93.9	31	675
(12)	204	194	—	92.3	29	650
(10)	196	187	—	90.7	28	620
(8)	188	179	—	89.5	27	600
(6)	180	171	—	87.1	26	580
(4)	173	165	—	85.5	25	550
(2)	166	158	—	83.5	24	530
(0)	160	152	—	81.7	24	515

表中 () 内の数値は、あまり用いられない範囲のもので参考として示したものである。
ブリネル硬さの [] 内の数値は、タングステンカーバイト球によるもので、それ以外は標準球による数値である。

Figures shown in () are uncommon and only for reference.
Figures shown in [] in Brinell hardness category are based on tungsten carbide balls, and others are based on standard type balls.

国際単位換算表

INTERNATIONAL SYSTEM OF UNITS

■ SI単位への切替えて問題となる単位の換算率表(太字の単位がSIによる単位である)

Unit conversion table for easier change into SI units (Bold face indicates SI unit)

圧力 Pressure

Pa	kPa	MPa	bar	kgf/cm ²	atm	mmH ₂ O	mmHg又は Torr
1	1 × 10 ⁻³	1 × 10 ⁻⁶	1 × 10 ⁻⁵	1.01972 × 10 ⁻⁵	9.86923 × 10 ⁻⁶	1.01972 × 10 ⁻¹	7.50062 × 10 ⁻³
1 × 10 ³	1	1 × 10 ⁻³	1 × 10 ⁻²	1.01972 × 10 ⁻²	9.86923 × 10 ⁻³	1.01972 × 10 ²	7.50062
1 × 10 ⁶	1 × 10 ³	1	1 × 10	1.01972 × 10	9.86923	1.01972 × 10 ⁵	7.50062 × 10 ³
1 × 10 ⁵	1 × 10 ²	1 × 10 ⁻¹	1	1.01972	9.86923 × 10 ⁻¹	1.01972 × 10 ⁴	7.50062 × 10 ²
9.80665 × 10 ⁴	9.80665 × 10	9.80665 × 10 ⁻²	9.80665 × 10 ⁻¹	1	9.67841 × 10 ⁻¹	1 × 10 ⁴	7.35559 × 10 ²
1.01325 × 10 ⁵	1.01325 × 10 ²	1.01325 × 10 ⁻¹	1.01325	1.03323	1	1.03323 × 10 ⁴	7.60000 × 10 ²
9.80665	9.80665 × 10 ⁻³	9.80665 × 10 ⁻⁶	9.80665 × 10 ⁻⁵	1 × 10 ⁻⁴	9.67841 × 10 ⁻⁵	1	7.35559 × 10 ⁻²
1.33322 × 10 ²	1.33322 × 10 ⁻¹	1.33322 × 10 ⁻⁴	1.33322 × 10 ⁻³	1.35951 × 10 ⁻³	1.31579 × 10 ⁻³	1.35951 × 10	1

注) Note) 1Pa = 1N/m²

力 Force

N	dyn	Kgf
1	1 × 10 ⁵	1.01972 × 10 ⁻¹
1 × 10 ⁻⁵	1	1.01972 × 10 ⁻⁶
9.80665	9.80665 × 10 ⁵	1

応力 Stress

Pa	MPa又はN/mm ²	kgf/mm ²	kgf/cm ²
1	1 × 10 ⁻⁶	1.01972 × 10 ⁻⁷	1.01972 × 10 ⁻⁵
1 × 10 ⁶	1	1.01972 × 10 ⁻¹	1.01972 × 10
9.80665 × 10 ⁶	9.80665	1	1 × 10 ²
9.80665 × 10 ⁴	9.80665 × 10 ⁻²	1 × 10 ⁻²	1

注) Note) 1Pa = 1N/m²

仕事・エネルギー・熱量 Work/Energy/Quantity of heat

J	kW·h	kgf·m	kcal
1	2.77778 × 10 ⁻⁷	1.01972 × 10 ⁻¹	2.38889 × 10 ⁻⁴
3.600 × 10 ⁶	1	3.67098 × 10 ⁵	8.6000 × 10 ²
9.80665	2.72407 × 10 ⁻⁶	1	2.34270 × 10 ⁻³
4.18605 × 10 ³	1.16279 × 10 ⁻³	4.26858 × 10 ²	1

注) Note) 1J = 1W·s, 1J = 1N·m 1cal = 4.18605J
(計量法による By the law of weights and measures)

仕事率(工率・動力) 熱流 Power (rate of production/motive power) /Heat flow rate

W	kgf·m/s	PS	kcal/h
1	1.01972 × 10 ⁻¹	1.35962 × 10 ⁻³	8.6000 × 10 ⁻¹
9.80665	1	1.33333 × 10 ⁻²	8.43371
7.355 × 10 ²	7.5 × 10	1	6.32529 × 10 ²
1.16279	1.18572 × 10 ⁻¹	1.58095 × 10 ⁻³	1

注) Note) 1W = 1J/s, PS: 仏馬力 French horse power
1PS = 0.7355kW
(計量法施工法による By the enforcement act for law of weights and measures)
1cal = 4.18605J
(計量法による By the law of weights and measures)

常用するはめあいの軸で用いる寸法許容差

DIMENSIONAL TOLERANCE FOR SHAFTS IN COMMON FITS

基準寸法の区分(mm) classification of standard dimensions(mm)		軸の公差域クラス Class of geometrical tolerance zone of shafts													
以上 Above	以下 Below	b9	c9	d8	d9	e7	e8	e9	f6	f7	f8	g5	g6	h5	h6
—	3	-140	-60	-20	-20	-14	-14	-14	-6	-6	-6	-2	-2	0	0
		-165	-85	-34	-45	-24	-28	-39	-12	-16	-20	-6	-8	-4	-6
3	6	-140	-70	-30	-30	-20	-20	-20	-10	-10	-10	-4	-4	0	0
		-170	-100	-48	-60	-32	-38	-50	-18	-22	-28	-9	-12	-5	-8
6	10	-150	-80	-40	-40	-25	-25	-25	-13	-13	-13	-5	-5	0	0
		-186	-116	-62	-76	-40	-47	-61	-22	-28	-35	-11	-14	-6	-9
10	14	-150	-95	-50	-50	-32	-32	-32	-16	-16	-16	-6	-6	0	0
		-193	-138	-77	-93	-50	-59	-75	-27	-34	-43	-14	-17	-8	-11
14	18	-150	-95	-50	-50	-32	-32	-32	-16	-16	-16	-6	-6	0	0
		-193	-138	-77	-93	-50	-59	-75	-27	-34	-43	-14	-17	-8	-11
18	24	-160	-110	-65	-65	-40	-40	-40	-20	-20	-20	-7	-7	0	0
		-212	-162	-98	-117	-61	-73	-92	-33	-41	-53	-16	-20	-9	-13
24	30	-160	-110	-65	-65	-40	-40	-40	-20	-20	-20	-7	-7	0	0
		-212	-162	-98	-117	-61	-73	-92	-33	-41	-53	-16	-20	-9	-13
30	40	-170	-120	-80	-80	-50	-50	-50	-25	-25	-25	-9	-9	0	0
		-232	-182	-119	-142	-75	-89	-112	-41	-50	-64	-20	-25	-11	-16
40	50	-180	-130	-119	-142	-75	-89	-112	-41	-50	-64	-20	-25	-11	-16
		-242	-192	-119	-142	-75	-89	-112	-41	-50	-64	-20	-25	-11	-16
50	65	-190	-140	-100	-100	-60	-60	-60	-30	-30	-30	-10	-10	0	0
		-264	-214	-146	-174	-90	-106	-134	-49	-60	-76	-23	-29	-13	-19
65	80	-200	-150	-146	-174	-90	-106	-134	-49	-60	-76	-23	-29	-13	-19
		-274	-224	-146	-174	-90	-106	-134	-49	-60	-76	-23	-29	-13	-19
80	100	-220	-170	-120	-120	-72	-72	-72	-36	-36	-36	-12	-12	0	0
		-307	-257	-174	-207	-107	-126	-159	-58	-71	-90	-27	-34	-15	-22
100	120	-240	-180	-174	-207	-107	-126	-159	-58	-71	-90	-27	-34	-15	-22
		-327	-267	-174	-207	-107	-126	-159	-58	-71	-90	-27	-34	-15	-22
120	140	-260	-200	-145	-145	-85	-85	-85	-43	-43	-43	-14	-14	0	0
		-360	-300	-208	-245	-125	-148	-185	-68	-83	-106	-32	-39	-18	-25
140	160	-280	-210	-145	-145	-85	-85	-85	-43	-43	-43	-14	-14	0	0
		-380	-310	-208	-245	-125	-148	-185	-68	-83	-106	-32	-39	-18	-25
160	180	-310	-230	-208	-245	-125	-148	-185	-68	-83	-106	-32	-39	-18	-25
		-410	-330	-208	-245	-125	-148	-185	-68	-83	-106	-32	-39	-18	-25
180	200	-340	-240	-170	-170	-100	-100	-100	-50	-50	-50	-15	-15	0	0
		-455	-355	-242	-285	-146	-172	-215	-79	-96	-122	-35	-44	-20	-29
200	225	-380	-260	-170	-170	-100	-100	-100	-50	-50	-50	-15	-15	0	0
		-495	-375	-242	-285	-146	-172	-215	-79	-96	-122	-35	-44	-20	-29
225	250	-420	-280	-242	-285	-146	-172	-215	-79	-96	-122	-35	-44	-20	-29
		-535	-395	-242	-285	-146	-172	-215	-79	-96	-122	-35	-44	-20	-29
250	280	-480	-300	-190	-190	-110	-110	-110	-56	-56	-56	-17	-17	0	0
		-610	-430	-271	-320	-162	-191	-240	-88	-108	-137	-40	-49	-23	-32
280	315	-540	-330	-271	-320	-162	-191	-240	-88	-108	-137	-40	-49	-23	-32
		-670	-460	-271	-320	-162	-191	-240	-88	-108	-137	-40	-49	-23	-32
315	355	-600	-360	-210	-210	-125	-125	-125	-62	-62	-62	-18	-18	0	0
		-740	-500	-299	-350	-182	-214	-265	-98	-119	-151	-43	-54	-25	-36
355	400	-680	-400	-299	-350	-182	-214	-265	-98	-119	-151	-43	-54	-25	-36
		-820	-540	-299	-350	-182	-214	-265	-98	-119	-151	-43	-54	-25	-36
400	450	-760	-440	-230	-230	-135	-135	-135	-68	-68	-68	-20	-20	0	0
		-915	-595	-327	-385	-198	-232	-290	-108	-131	-165	-47	-60	-27	-40
450	500	-840	-480	-327	-385	-198	-232	-290	-108	-131	-165	-47	-60	-27	-40
		-995	-635	-327	-385	-198	-232	-290	-108	-131	-165	-47	-60	-27	-40

備考：表中の各段で、上側の数値は上の寸法許容差、下側の数値は下の寸法許容差を示す。

NOTE: Values shown in the upper portion of respective lines are upper dimensional tolerance, while values shown in the lower portion of respective lines are lower dimensional tolerance.

単位 Units: μm

軸の公差域クラス Class of geometrical tolerance zone of shafts																
h7	h8	h9	js5	js6	js7	k5	k6	m5	m6	n6	p6	r6	s6	t6	u6	x6
0	0	0	±2	±3	±5	+4	+6	+6	+8	+10	+12	+16	+20	—	+24	+26
-10	-14	-25				0	0	+2	+2	+4	+6	+10	+14		+18	+20
0	0	0	±2.5	±4	±6	+6	+9	+9	+12	+16	+20	+23	+27		+31	+36
-12	-18	-30				+1	+1	+4	+4	+8	+12	+15	+19	+23	+28	
0	0	0	±3	±4.5	±7	+7	+10	+12	+15	+19	+24	+28	+32	—	+37	+43
-15	-22	-36				+1	+1	+6	+6	+10	+15	+19	+23		+28	+34
0	0	0	±4	±5.5	±9	+9	+12	+15	+18	+23	+29	+34	+39	—	+44	+51
-18	-27	-43				+1	+1	+7	+7	+12	+18	+23	+28		+33	+40
0	0	0	±4.5	±6.5	±10	+11	+15	+17	+21	+28	+35	+41	+48	—	+54	+67
-21	-33	-52				+2	+2	+8	+8	+15	+22	+28	+35		+41	+54
0	0	0	±5.5	±8	±12	+13	+18	+20	+25	+33	+42	+50	+59	+54	+61	+77
-25	-39	-62				+2	+2	+9	+9	+17	+26	+34	+43		+48	+64
0	0	0	±6.5	±9.5	±15	+15	+21	+24	+30	+39	+51	+60	+72	+54	+76	+86
-30	-46	-74				+2	+2	+11	+11	+20	+32	+41	+53		+66	+87
0	0	0	±7.5	±11	±17	+18	+25	+28	+35	+45	+59	+73	+93	+54	+106	+124
-35	-54	-87				+3	+3	+13	+13	+23	+37	+51	+71		+91	+124
0	0	0	±9	±12.5	±20	+21	+28	+33	+40	+52	+68	+88	+117	+54	+146	+166
-40	-63	-100				+3	+3	+15	+15	+27	+43	+63	+92		+113	+146
0	0	0	±10	±14.5	±23	+24	+33	+37	+46	+60	+79	+106	+151	+54	+166	+184
-46	-72	-115				+4	+4	+17	+17	+31	+50	+77	+122		+159	+184
0	0	0	±11.5	±16	±26	+27	+36	+43	+52	+66	+88	+126	+169	+54	+200	+220
-52	-81	-130				+4	+4	+20	+20	+34	+56	+94	+133		+179	+220
0	0	0	±12.5	±18	±28	+29	+40	+46	+57	+73	+98	+144	+199	+54	+240	+264
-57	-89	-140				+4	+4	+21	+21	+37	+62	+108	+154		+214	+264
0	0	0	±13.5	±20	±31	+32	+45	+50	+63	+80	+108	+166	+231	+54	+280	+312
-63	-97	-155				+5	+5	+23	+23	+40	+68	+126	+177		+254	+312

BT series

HSK series

ST series

Versatile Tool

Cutting Tool

Accessories

Data

常用するはめあいの穴で用いる寸法許容差

DIMENSIONAL TOLERANCE FOR HOLES IN COMMON FITS

基準寸法の区分(mm) classification of standard dimensions (mm)		穴の公差域クラス Class of geometrical tolerance zone of holes															
以上 Above	以下 Below	B10	C9	C10	D8	D9	D10	E7	E8	E9	F6	F7	F8	G6	G7	H6	H7
—	3	+180	+85	+100	+34	+45	+60	+24	+28	+39	+12	+16	+20	+8	+12	+6	+10
		+140	+60	+60	+20	+20	+20	+14	+14	+14	+6	+6	+6	+2	+2	0	0
3	6	+188	+100	+118	+48	+60	+78	+32	+38	+50	+18	+22	+28	+12	+16	+8	+12
		+140	+70	+70	+30	+30	+30	+20	+20	+20	+10	+10	+10	+4	+4	0	0
6	10	+208	+116	+138	+62	+76	+98	+40	+47	+61	+22	+28	+35	+14	+20	+9	+15
		+150	+80	+80	+40	+40	+40	+25	+25	+25	+13	+13	+13	+5	+5	0	0
10	14	+220	+138	+165	+77	+93	+120	+50	+59	+75	+27	+34	+43	+17	+24	+11	+18
		+150	+95	+95	+50	+50	+50	+32	+32	+32	+16	+16	+16	+6	+6	0	0
14	18																
18	24	+244	+162	+194	+98	+117	+149	+61	+73	+92	+33	+41	+53	+20	+28	+13	+21
		+160	+110	+110	+65	+65	+65	+40	+40	+40	+20	+20	+20	+7	+7	0	0
24	30																
30	40	+270	+182	+220													
		+170	+120	+120	+119	+142	+180	+75	+89	+112	+41	+50	+64	+25	+34	+16	+25
40	50	+280	+192	+230	+80	+80	+80	+50	+50	+50	+25	+25	+25	+9	+9	0	0
		+180	+130	+130													
50	65	+310	+214	+260													
		+190	+140	+140	+146	+174	+220	+90	+106	+134	+49	+60	+76	+29	+40	+19	+30
65	80	+320	+224	+270	+100	+100	+100	+60	+60	+60	+30	+30	+30	+10	+10	0	0
		+200	+150	+150													
80	100	+360	+257	+310													
		+220	+170	+170	+174	+207	+260	+107	+126	+159	+58	+71	+90	+34	+47	+22	+35
100	120	+380	+267	+320	+120	+120	+120	+72	+72	+72	+36	+36	+36	+12	+12	0	0
		+240	+180	+180													
120	140	+420	+300	+360													
		+260	+200	+200													
140	160	+440	+310	+370	+208	+245	+305	+125	+148	+185	+68	+83	+106	+39	+54	+25	+40
		+280	+210	+210	+145	+145	+145	+85	+85	+85	+43	+43	+43	+14	+14	0	0
160	180	+470	+330	+390													
		+310	+230	+230													
180	200	+525	+355	+425													
		+340	+240	+240													
200	225	+565	+375	+445	+242	+285	+355	+146	+172	+215	+79	+96	+122	+44	+61	+29	+46
		+380	+260	+260	+170	+170	+170	+100	+100	+100	+50	+50	+50	+15	+15	0	0
225	250	+605	+395	+465													
		+420	+280	+280													
250	280	+690	+430	+510													
		+480	+300	+300	+271	+320	+400	+162	+191	+240	+88	+108	+137	+49	+69	+32	+52
280	315	+750	+460	+540	+190	+190	+190	+110	+110	+110	+56	+56	+56	+17	+17	0	0
		+540	+330	+330													
315	355	+830	+500	+590													
		+600	+360	+360	+299	+350	+440	+182	+214	+265	+98	+119	+151	+54	+75	+36	+57
355	400	+910	+540	+630	+210	+210	+210	+125	+125	+125	+62	+62	+62	+18	+18	0	0
		+680	+400	+400													
400	450	+1010	+595	+690													
		+760	+440	+440	+327	+385	+480	+198	+232	+290	+108	+131	+165	+60	+83	+40	+63
450	500	+1090	+635	+730	+230	+230	+230	+135	+135	+135	+68	+68	+68	+20	+20	0	0
		+840	+480	+480													

備考：表中の各段で、上側の数値は上の寸法許容差、下側の数値は下の寸法許容差を示す。

NOTE: Values shown in the upper portion of respective lines are upper dimensional tolerance, while values shown in the lower portion of respective lines are lower dimensional tolerance.

単位 Units: μm

穴の公差域クラス Class of geometrical tolerance zone of holes																	
H8	H9	H10	JS6	JS7	K6	K7	M6	M7	N6	N7	P6	P7	R7	S7	T7	U7	X7
+14 0	+25 0	+40 0	±3	±5	0 -6	0 -10	-2 -8	-2 -12	-4 -10	-4 -14	-6 -12	-6 -16	-10 -20	-14 -24	—	-18 -28	-20 -30
+18 0	+30 0	+48 0	±4	±6	+2 -6	+3 -9	-1 -9	0 -12	-5 -13	-4 -16	-9 -17	-8 -20	-11 -23	-15 -27	—	-19 -31	-24 -36
+22 0	+36 0	+58 0	±4.5	±7	+2 -7	+5 -10	-3 -12	0 -15	-7 -16	-4 -19	-12 -21	-9 -24	-13 -28	-17 -32	—	-22 -37	-28 -43
+27 0	+43 0	+70 0	±5.5	±9	+2 -9	+6 -12	-4 -15	0 -18	-9 -20	-5 -23	-15 -26	-11 -29	-16 -34	-21 -39	—	-26 -44	-33 -51 -38 -56
+33 0	+52 0	+84 0	±6.5	±10	+2 -11	+6 -15	-4 -17	0 -21	-11 -24	-7 -28	-18 -31	-14 -35	-20 -41	-27 -48	—	-33 -54 -61	-46 -67 -56 -77
+39 0	+62 0	+100 0	±8	±12	+3 -13	+7 -18	-4 -20	0 -25	-12 -28	-8 -33	-21 -37	-17 -42	-25 -50	-34 -59	-39 -64 -70	-51 -76 -86	—
+46 0	+74 0	+120 0	±9.5	±15	+4 -15	+9 -21	-5 -24	0 -30	-14 -33	-9 -39	-26 -45	-21 -51	-30 -60 -62	-42 -72 -48	-55 -85 -64	-76 -106 -91	-91 -121
+54 0	+87 0	+140 0	±11	±17	+4 -18	+10 -25	-6 -28	0 -35	-16 -38	-10 -45	-30 -52	-24 -59	-38 -73 -41 -76	-58 -93 -66 -101	-78 -113 -91 -126	-111 -146 -131 -166	—
+63 0	+100 0	+160 0	±12.5	±20	+4 -21	+12 -28	-8 -33	0 -40	-20 -45	-12 -52	-36 -61	-28 -68	-48 -88 -50 -90 -53 -93	-77 -117 -85 -125 -93 -133	-107 -147 -119 -159 -131 -171	—	—
+72 0	+115 0	+185 0	±14.5	±23	+5 -24	+13 -33	-8 -37	0 -46	-22 -51	-14 -60	-41 -70	-33 -79	-60 -106 -63 -109 -67 -113	-105 -151 -113 -159 -123 -169	—	—	—
+81 0	+130 0	+210 0	±16	±26	+5 -27	+16 -36	-9 -41	0 -52	-25 -57	-14 -66	-47 -79	-36 -88	-74 -126 -78 -130	—	—	—	—
+89 0	+140 0	+230 0	±18	±28	+7 -29	+17 -40	-10 -46	0 -57	-26 -62	-16 -73	-51 -87	-41 -98	-87 -144 -93 -150	—	—	—	—
+97 0	+155 0	+250 0	±20	±31	+8 -32	+18 -45	-10 -50	0 -63	-27 -67	-17 -80	-55 -95	-45 -108	-103 -166 -109 -172	—	—	—	—

BT series

HSK series

ST series

Versatile Tool

Cutting Tool

Accessories

Data

タップ下穴表

DRILL DIAMETERS FOR TAPPING

メートル並目ネジ Metric coarse screw thread

ネジサイズ Nominal	ドリル径 Drill diameter	ネジサイズ Nominal	ドリル径 Drill diameter	ネジサイズ Nominal	ドリル径 Drill diameter	ネジサイズ Nominal	ドリル径 Drill diameter
M1 ×0.25	0.75	M2.5×0.45	2.10	M9×1.25	7.80	M27×3	24.0
M1.1×0.25	0.85	M2.6×0.45	2.20	M10×1.5	8.50	M30×3.5	26.5
M1.2×0.25	0.95	M3 ×0.5	2.50	M11×1.5	9.50	M33×3.5	29.5
M1.4×0.3	1.10	M3.5×0.6	2.90	M12×1.75	10.3	M36×4	32.0
M1.6×0.35	1.25	M4 ×0.7	3.30	M14×2	12.0	M39×4	35.0
M1.7×0.35	1.35	M4.5×0.75	3.80	M16×2	14.0	M42×4.5	37.5
M1.8×0.35	1.45	M5 ×0.8	4.20	M18×2.5	15.5	M45×4.5	40.5
M2 ×0.4	1.60	M6 ×1.0	5.00	M20×2.5	17.5	M48×5	43.0
M2.2×0.45	1.75	M7 ×1.0	6.00	M22×2.5	19.5		
M2.3×0.4	1.90	M8 ×1.25	6.80	M24×3	21.0		

メートル細目ネジ Metric fine screw thread

ネジサイズ Nominal	ドリル径 Drill diameter	ネジサイズ Nominal	ドリル径 Drill diameter	ネジサイズ Nominal	ドリル径 Drill diameter	ネジサイズ Nominal	ドリル径 Drill diameter
M1 ×0.2	0.80	M11×0.75	10.3	M25×1.5	23.5	M39×1.5	37.5
M1.1×0.2	0.90	M12×1.5	10.5	M25×1.0	24.0	M40×3.0	37.0
M1.2×0.2	1.00	M12×1.25	10.8	M26×1.5	24.5	M40×2.0	38.0
M1.4×0.2	1.20	M12×1.0	11.0	M27×2.0	25.0	M40×1.5	38.5
M1.6×0.2	1.40	M14×1.5	12.5	M27×1.5	25.5	M42×4.0	38.0
M1.8×0.2	1.60	M14×1.0	13.0	M27×1.0	26.0	M42×3.0	39.0
M2 ×0.25	1.75	M15×1.5	13.5	M28×2.0	26.0	M42×2.0	40.0
M2.2×0.25	1.95	M15×1.0	14.0	M28×1.5	26.5	M42×1.5	40.5
M2.5×0.35	2.20	M16×1.5	14.5	M28×1.0	27.0	M45×4.0	41.0
M3 ×0.35	2.70	M16×1.0	15.0	M30×3.0	27.0	M45×3.0	42.0
M3.5×0.35	3.20	M17×1.5	15.5	M30×2.0	28.0	M45×2.0	43.0
M4 ×0.5	3.50	M17×1.0	16.0	M30×1.5	28.5	M45×1.5	43.5
M4.5×0.5	4.00	M18×2.0	16.0	M30×1.0	29.0	M48×4.0	44.0
M5 ×0.5	4.50	M18×1.5	16.5	M32×2.0	30.0	M48×3.0	45.0
M5.5×0.5	5.00	M18×1.0	17.0	M32×1.5	30.5	M48×2.0	46.0
M6 ×0.75	5.30	M20×2.0	18.0	M33×3.0	30.0	M48×1.5	46.5
M7 ×0.75	6.30	M20×1.5	18.5	M33×2.0	31.0	M50×3.0	47.0
M8 ×1.0	7.00	M20×1.0	19.0	M33×1.5	31.5	M50×2.0	48.0
M8 ×0.75	7.30	M22×2.0	20.0	M35×1.5	33.5	M50×1.5	48.5
M9 ×1.0	8.00	M22×1.5	20.5	M36×3.0	33.0		
M9 ×0.75	8.30	M22×1.0	21.0	M36×2.0	34.0		
M10 ×1.25	8.80	M24×2.0	22.0	M36×1.5	34.5		
M10 ×1.0	9.00	M24×1.5	22.5	M38×1.5	36.5		
M10 ×0.75	9.30	M24×1.0	23.0	M39×3.0	36.0		
M11 ×1.0	10.0	M25×2.0	23.0	M39×2.0	37.0		

※ この表のドリル径を使って加工する場合は、加工条件によりドリル穴の寸法精度が変化するので、加工穴を測定し、下穴として不適当なときは、ドリル径を変更する必要があります。

※ We remind you upon using the drill diameters shown in this table, that the processed hole should be measured since the size accuracy of a drill hole may change due to the milling condition, and that if found to be inappropriate for tapping, the drill diameter must be corrected accordingly.

六角穴付ボルトに対する座グリ・ボルト穴寸法表

DIMENSIONS OF COUNTERBORING FOR HEXAGON SOCKET HEAD CAP SCREW AND BOLT HOLE

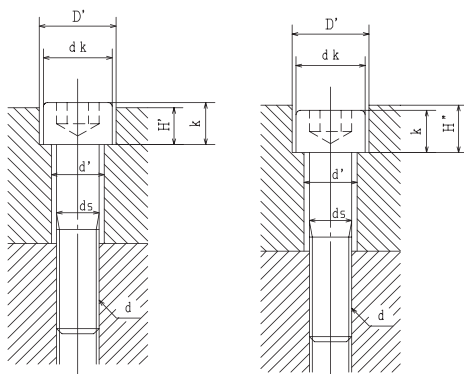

ネジサイズ(d) Nominal dimensions of thread	ds	d'	dk	D'	k	H'	H''
M3	3	3.4	5.5	6.5	3	2.7	3.3
M4	4	4.5	7	8	4	3.6	4.4
M5	5	5.5	8.5	9.5	5	4.6	5.4
M6	6	6.6	10	11	6	5.5	6.5
M8	8	9	13	14	8	7.4	8.6
M10	10	11	16	17.5	10	9.2	10.8
M12	12	14	18	20	12	11	13
M14	14	16	21	23	14	12.8	15.2
M16	16	18	24	26	16	14.5	17.5
M18	18	20	27	29	18	16.5	19.5
M20	20	22	30	32	20	18.5	21.5
M22	22	24	33	35	22	20.5	23.5
M24	24	26	36	39	24	22.5	25.5
M27	27	30	40	43	27	25	29
M30	30	33	45	48	30	28	32