

正面フライスアーバB型

FACE MILL ARBOR (Type B)

BT[Ⓝ] - FMB[Ⓞ] - L

SHOWA TOOL CO., LTD.



BT series
BTシリーズ

www.showatool.com

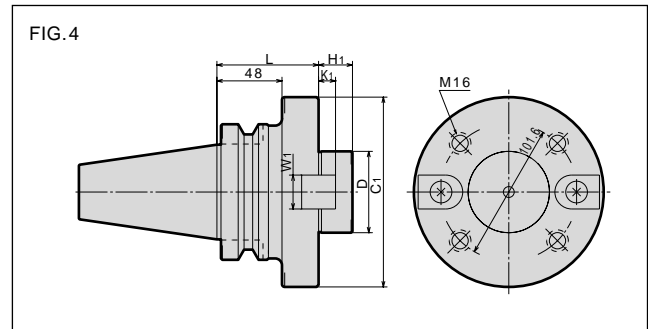
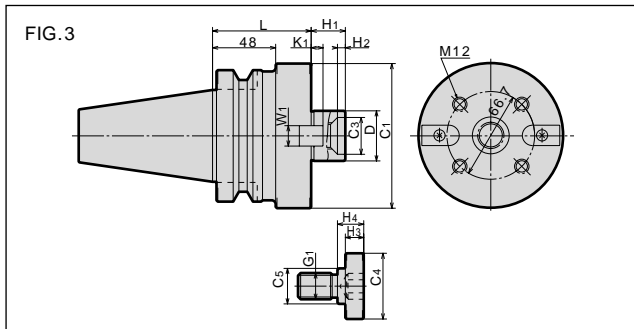
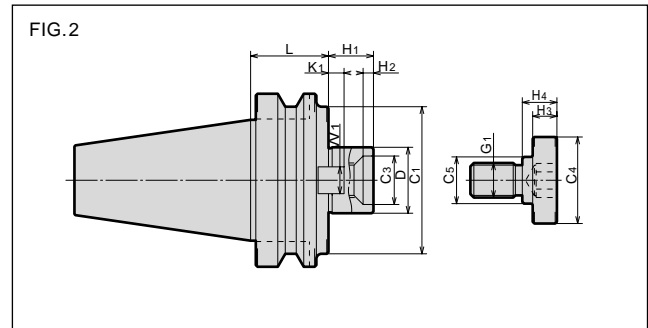
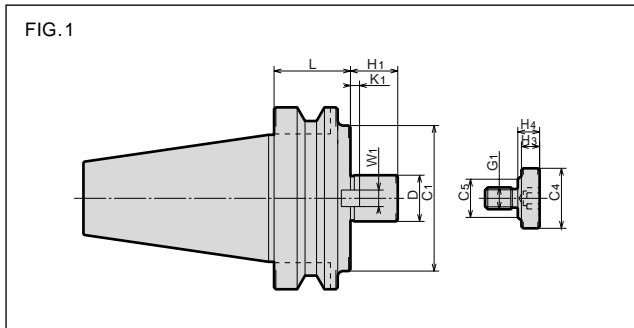

CODE	FIG.	D(h6)	L	C1	C3	H1	H2	KEY		G1	CLAMP BOLT				N/W (kg)	PRICE (Yen)		
								W1	K1		C4	C5	H3	H4				
BT40	-FMB25.4 -060	11022	1	25.4	60	80	26		9.5	5	M12	33	23	10	12	1.3	20,700	
	-105	11024			105											3.3		
	-FMB38.1 -060	11026	2	38.1	60	85	28	26	6	15.9	9	M20	50	27	14	20	2.6	21,900
	-FMB27 -060	11028			60												2.3	
	-105	11030	105	3.3														
	-FMB40 -060	11032	2	40	60	85	28	26	6	16	8.5	M20	50	27	14	20	2.6	21,900
-FMB25.4 -045	13032	45			4.1													
BT50	-090	13034	1	25.4	90	80	26		9.5	5	M12	33	23	10	12	6.1	29,900	
	-150	13036			150											8.3		
	-FMB38.1 -045	13038			45											4.4		
	-075	13040	2	38.1	75	85	28	26	6	15.9	9	M20	50	27	14	20	5.7	28,800
	-105	13042			105												7.0	
	-FMB38.1F-075	13044			3												38.1	
	-FMB27 -045	13046	1	27	45	80	26		12	6	M12	33	23	10	12	4.1	26,500	
	-090	13048			90											5.9		
	-150	13050			150											8.3		
	-FMB40 -045	13052	2	40	45	85	28	26	6	16	8.5	M20	50	27	14	20	4.4	26,500
	-075	13054			75												5.7	
	-105	13056			105												7.1	
	-FMB40F -075	13058	3	40	75	110	28	26	6	16	8.5	M20	50	27	14	20	6.7	35,700
	-FMB60 -075	13060			4												60	

注: サンドビグカッタ用

NOTE: For Sandvik cutters.

BT40-FMB 25.4-060 ご注文例 Ordering Example

GL長さ L G.L. Length
インロー径 φD
呼称 Name
シャンクサイズ Shank Size