

モーステーパーホルダB型

MORSE TAPER HOLDER (Type B)

SHOWA TOOL CO., LTD.

BT (No.) - MTB (No.) - L

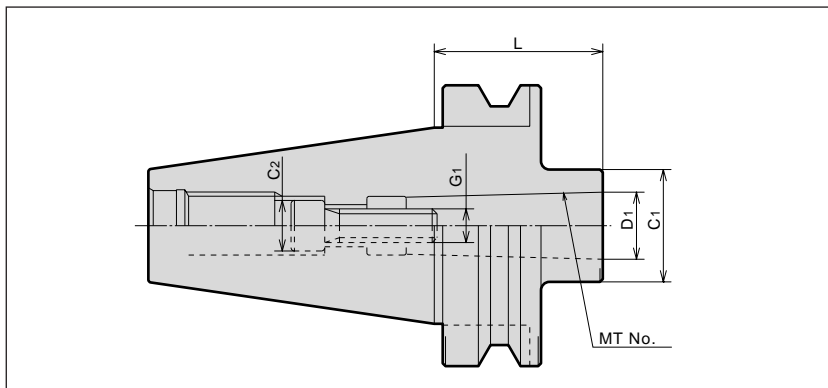

CODE		MT No.	L	D1	C1	C2	G1	N/W (kg)	PRICE (Yen)	
BT40	-MTB1-045	11167	1	45	12.065	25	10	M6	1.0	16,100
	-MTB2-045	11168	2	45	17.780	32	14	M10	1.0	
BT50	-MTB1-045	13332	1	45	12.065	25	10	M6	3.6	25,300
	-MTB2-045	13334	2	45	17.780	32	16	M10	3.6	
	-MTB3-060	13336	3	60	23.825	40	18	M12	3.7	26,500
	-MTB4-075	13338	4	75	31.267	50	20.5	M16	3.7	

注: 引ネジ式MTシャンク刃具を使用する。

NOTE: For drawing thread type Morse taper shank cutting tools.

ご注文例 Ordering Example

BT40-MTB 1 -045

- GL長さ L G.L. Length
- MT No.
- 呼称 Name
- シャンクサイズ Shank Size