

# 小径ミーリングチャック (ロングタイプ)

SHOKEI MILLING CHUCK (Long Type)

SHOWA TOOL CO., LTD.

## BT50-CTM<sup>Ⓢ</sup> MAX - L

センタースルー対応可能  
Thru-the-tool Coolant Available

スキマスルー対応可能  
Thru-the-groove Coolant Available

P. 7

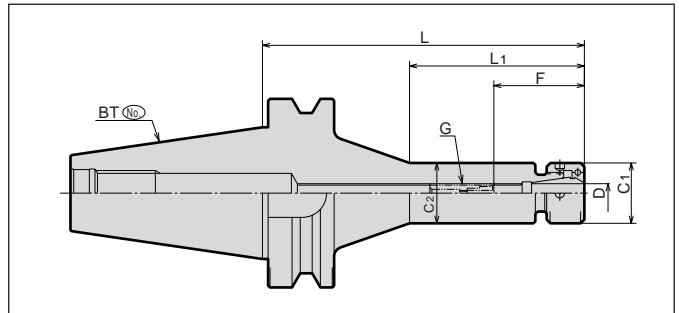

CODE	D GRIPPING RANGE	L	L1	C1	C2	G	F		COLLET SIZE	ADJUST SCREW	N/W (kg)	PRICE (Yen)	
							MIN.	MAX.					
BT50	-CTM10-225	13522	225	150	32	32	M10 x 1.5	30	60	CR10-Ⓢ	OH-M10	5.0	54,900
	-255	13524	255	180								5.1	59,400
	-285	13526	285	190								5.5	65,000
	-CTM13-225	13528	225	150	36	36	M12 x 1.5	35	70	CR13-Ⓢ	OH-M12	5.2	57,200
	-255	13530	255	180								5.4	61,600
	-285	13532	285	190								5.9	67,200
	-CTM16-225	13534	225	150	44	42	M18 x 1.5	40	65	CR16-Ⓢ	OH-M18	5.6	59,400
	-255	13536	255	180								6.0	63,900
	-285	13538	285	190								6.5	69,500

注:1. 全サイズスピンドルスルーにて使用可能です。(調整ネジは、ORタイプを別途ご注文下さい。)→140頁

2. CRコレットは138頁、チャックレンチは142頁をご覧ください。

NOTE:1. Coolant can be supplied through the pull stud. OR type adjust screw is used for thru-spindle coolant applications and sold separately. Please refer to P.140.

2. Please refer to P.138 for CR collet and P.142 for chuck wrench.

BT50-CTM10-225	ご注文例 Ordering Example
GL長さ L G.L. Length	
Max. φD	
呼称 Holder's Name	
シャンクサイズ Shank Size	