

マイクロチャック Hシリーズ (ミーリングチャック)

MICRON CHUCK H series (Milling Chuck)
SHOWA TOOL CO., LTD.

BTF (No.) -HPC (D) H-L

3 15

(オプション) センタースルー対応可能
(Optional) Thru-the-tool Coolant Available

(オプション) スキマスルー対応可能
(Optional) Thru-the-groove Coolant Available

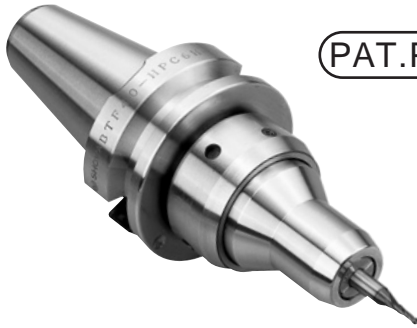

PAT.P

高速 (H) シリーズ 20,000min⁻¹ 対応 (Gタイプは、30,000min⁻¹ 対応)
Made for speeds up to 20,000 min⁻¹. (30,000 min⁻¹ for G-type)

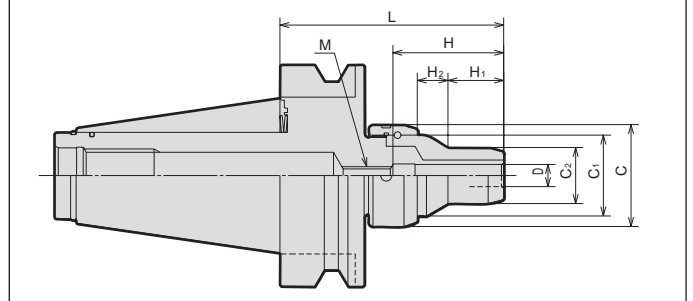

A級 GRADE A

CODE	D	L	H	C	C1	C2	H1	H2	M	N/W (kg)	PRICE (Yen)				
Max. 20,000 min ⁻¹															
BTF30	-HPC03H-060A	14627	3	15	46	36.5	25	10.3	6.7	-	0.9	62,700			
	-HPC04H-060A	14628	4							M5					
	-HPC06H-060A	14629	6												
	-HPC08H-060A	14630	8												
	-HPC10H-060A	14631	10												
	-HPC12H-060A	14632	12												
Max. 20,000 min ⁻¹															
BTF40	-HPC03H-060A	14926	3	60	46	36.5	25	10.3	6.7	-	1.4	65,000			
	-HPC03H-090A	14932		90				25	14		1.5				
	-HPC03H-120A	14925		120				25	14		1.7				
	-HPC04H-060A	14927	4	60				10.3	6.7		1.4				
	-HPC04H-090A	14933		90				25	14		1.5				
	-HPC04H-120A	14943		120				25	14		1.7				
	-HPC06H-060A	14928	6	60				10.3	6.7		M5		1.4		
	-HPC06H-090A	14934		90				25	14				1.5		
	-HPC06H-120A	14944		120				25	14				1.7		
	-HPC08H-060A	14929	8	60				10.3	6.7		M6		1.4		
	-HPC08H-090A	14935		90				25	14				1.5		
	-HPC08H-120A	14945		120				25	14				1.7		
	-HPC10H-060A	14930	10	60				10.3	6.7		M8		1.4		
	-HPC10H-090A	14936		90				25	14				1.5		
	-HPC10H-120A	14946		120				25	14				1.7		
	-HPC12H-060A	14931	12	60				55	32		12.2		4.8	M10	1.4
	-HPC12H-090A	14937		90											1.5
	-HPC12H-120A	14947		120											25
Max. 12,000 min ⁻¹															
BTF50	-HPC03H-105A		3	105	46	36.5	25	25	14	-	4.0	78,400			
	-HPC03H-150A			150							4.6				
	-HPC04H-105A	15094		4							105		4.0		
	-HPC04H-150A	15675	150								4.6				
	-HPC06H-105A	15095	105								4.0				
	-HPC06H-150A	15676	6	150							M5		4.6		
	-HPC08H-105A	15096		105									4.0		
	-HPC08H-150A	15677		150									4.6		
	-HPC10H-105A	15097	10	105							M6		4.0		
	-HPC10H-150A	15678		150									4.6		
	-HPC12H-105A	15098		12									105	M8	4.0
	-HPC12H-150A	15679	150								4.6				

Gタイプ G-type

CODE		D	L	H	C	C1	C2	H1	H2	M	N/W (kg)	PRICE (Yen)															
Max. 30,000 min ⁻¹																											
BTF30	-HPC03H-060G	14647	3	60	46	36.5	25	10.3	6.7	-	0.9	81,800															
	-HPC04H-060G	14648	4							15			M5														
	-HPC06H-060G	14649	6							37.5			M6														
	-HPC08H-060G	14650	8							50			M8														
	-HPC10H-060G	14651	10							55			M10														
-HPC12H-060G	14652	12			32	12.2	4.8																				
Max. 30,000 min ⁻¹																											
BTF40	-HPC03H-060G	14948	3	60	46	36.5	25	10.3	6.7	-	1.4	87,600															
	-HPC03H-090G	14950		90				25	14		1.5																
	-HPC03H-120G	14951		120				10.3	6.7		1.7		93,200														
	-HPC04H-060G	14952	4	60				46	36.5	25	10.3	6.7	-	1.4	87,600												
	-HPC04H-090G	14954		90							25	14		1.5													
	-HPC04H-120G	14955		120							10.3	6.7		1.7		93,200											
	-HPC06H-060G	14956	6	60							46	36.5	25	10.3	6.7	M5	1.4	87,600									
	-HPC06H-090G	14958		90										25	14		1.5										
	-HPC06H-120G	14959		120										10.3	6.7		1.7		93,200								
	-HPC08H-060G	14960	8	60										46	36.5	25	10.3	6.7	M6	1.4	87,600						
	-HPC08H-090G	14962		90													25	14		1.5							
	-HPC08H-120G	14963		120													10.3	6.7		1.7		93,200					
	-HPC10H-060G	14964	10	60													46	36.5	25	10.3	6.7	M8	1.4	87,600			
	-HPC10H-090G	14966		90																25	14		1.5				
	-HPC10H-120G	14967		120																10.3	6.7		1.7		93,200		
	-HPC12H-060G	14968	12	60																46	36.5	32	12.2	4.8	M10	1.4	87,600
	-HPC12H-090G	14970		90																			25	14		1.5	
-HPC12H-120G	14971	120		10.3	6.7	1.7	93,200																				

注:1. チャックレンチは142頁をご覧ください。(別途ご注文下さい。)

2. 調整ネジのランニング切替中につき、在庫品には旧タイプ(ネジ無し)品もあります。

3. 調整ネジは受注生産致します。

4. 表記の許容回転数は、機械の剛性と刃物のバランスに大きく左右されますので、表記中の回転数と異なる場合があります。

NOTE:1. Please refer to P.142 for chuck wrench. (Sold separately.)

2. Former version of "H" series Micron Chucks do not have the thread for the adjust screw.

3. Adjust Screws are manufactured to order.

4. The above-mentioned maximum speed will vary depending rigidity of the machine and balance of cutter.
An adequate cutting condition should be selected for each case.

BTF30-HPC03H-060A		ご注文例 Ordering Example	
L	等級 Grade		
	GL長さ L G.L. Length		
	Hシリーズ H series		
	刃長シャック径φD Cutter's Shank Dia.		
	呼称 Holder's Name		
	シャックサイズ Shank Size		