

ハードチャック (コレットホルダ)

HARD CHUCK (Collet Holder)

SHOWA TOOL CO., LTD.

BTF[Ⓝ]-CTH[Ⓧ]-L

センタースルー対応可能
Thru-the-tool Coolant Available

P. 5 P. 15

特長 Features

聖和精密工機のハードチャックはツーリングに要求される条件(剛性・求心性・操作性・経済性)を総合的に考えて設計していますので、あらゆる条件にもハイレベルで調和を計り無理のないツールレイアウトが可能です。

- The ball screw structure provides high clamping power.
- Easy handling.
- High accuracy and rigidity are kept long.

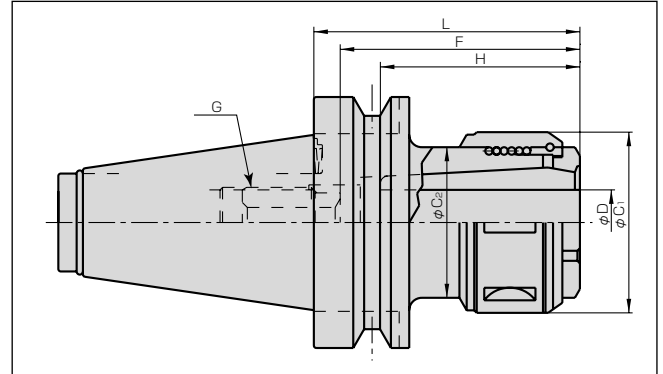

CODE	D	L	C1	C2	H	G	F		SPRING COLLET	ADJUST SCREW	N/W (kg)	PRICE (Yen)		
							MIN.	MAX.						
BTF40	16	-CTH16-105	15070	105	52	50	50	M18×1.5	50	80	C16-(16)	OH-M18	1.9	62,800
		-135	15071	135									2.3	65,000
		-165	15072	165									2.7	67,200
	20	-CTH20-90	15073	90	60	54	50	M18×1.5	50	75	C20-(20)	OH-M18	1.9	69,500
		-120	15074	120									2.4	69,500
		-CTH25-105	15075	105									68	62
	-135	15076	135	2.9	69,500									
	-165	15077	165	3.5	71,700									
32	-CTH32-105	15078	105	80	62	70	M18×1.5	80	95	CS32-(32)	OH-M18	2.6	69,500	
	-135	15079	135									3.3	71,700	
BTF50	16	-CTH16-105	15270	105	52	50	50	M18×1.5	50	100	C16-(16)	OH-M18	4.2	78,400
		-135	15271	135									4.7	81,400
		-165	15272	165									5.2	84,000
	20	-CTH20-105	15273	105	60	54	50	M18×1.5	50	100	C20-(20)	OH-M18	4.6	80,500
		-135	15274	135									5.1	83,700
		-165	15275	165									5.6	87,000
	25	-CTH25-105	15276	105	68	62	68	M28×1.5	68	100	C25-(25)	OH-M28	4.6	80,500
		-135	15277	135									5.2	83,700
		-165	15278	165									6.0	87,000
	32	-CTH32-105	15279	105	80	67.5	80	M28×1.5	80	100	C32-(32)	OH-M28	4.8	83,400
		-135	15280	135									75	5.9
		-165	15281	165	95	79.5	90	M36×1.5	90	110	C42-(42)	OH-M36	6.9	90,500
		-CTH42-105	15282	105									79.5	5.2
	-135	15283	135	87	6.5	95,200								
-165	15284	165	87	7.7	98,900									

注:1. 全サイズスピンドルスルーにて使用可能です。(調整ネジはORタイプを別途ご注文下さい。)

2. チャックレンチは、142頁をご覧ください。
3. スプリングコレットは137頁、ストレートコレットは141頁、調整ねじは140頁をご覧ください。

NOTE:1. Coolant can be supplied through the pull stud. OR type adjust screw is used for thru-spindle coolant applications and sold separately.

2. Please refer to P.142 for chuck wrench.
3. Please refer to P.137 for spring collet and P.141 for straight collet and P.140 for adjust screw.

BTF40-CTH20-120 ご注文例 Ordering Example

GL長さ L G.L. Length
刃具シャック径φD Cutter's Shank Dia.
呼称 Holder's Name
シャックサイズ Shank Size