

マイクロチャック (ミーリングチャック)

MICRON CHUCK (Milling Chuck)
SHOWA TOOL CO., LTD.

BTF No. -HPC D -L

P.1 P.15

センタースルー対応可能
Thru-the-tool Coolant Available

スキマスルー対応可能
Thru-the-groove Coolant Available



(PAT.P)

振れ精度
run-out

(UNIT: μm)		
等級 GRADE	口元 NOSE	3D先 3D POINT
A	3	5

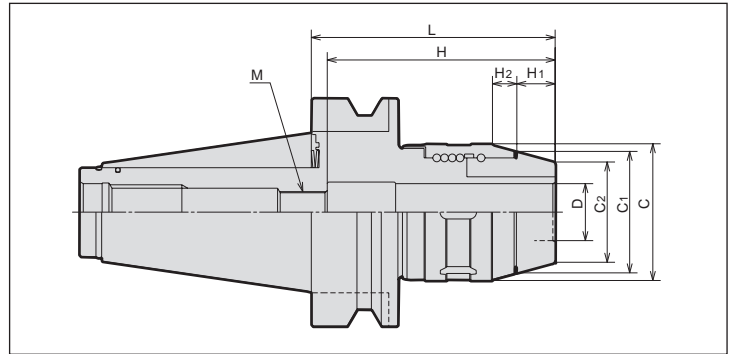

A級 GRADE A

CODE	D	L	H	C	C1	C2	H1	H2	M	N/W (kg)	PRICE (Yen)	
Max. 10,000 min ⁻¹												
BTF30	HPC16 100A	14633	16	100	85	56	45.9	34	16	10	M10 x 1.0	1.4
	HPC20 100A	14634	20									1.3
Max. 10,000 min ⁻¹												
BTF40	HPC16 090A	15020	16	90	85	56	45.9	34	16	10	M10 x 1.0	1.8
	HPC16 120A	15021		120								2.2
	HPC20 090A	15022	20	90	80	62	53.3	38	17	10.5	M18 x 1.0	1.7
	HPC20 120A	15023		120								2.1
	HPC25 105A	14939	25	105	90	70	61.3	44	17	10.5	M18 x 1.0	2.0
	HPC25 135A	14941		135								2.5
	HPC32 105A	15024	32	105	90	78	68.6	52	19	11.5	M18 x 1.0	2.2
	HPC32 135A	14942		135								2.5
	HPC16S 105A *	14938	16	105	85	62	53.3	44	17	10.5	M10 x 1.0	2.3
	HPC20S 105A *	15026	20	105	85	62	53.3	44	17	10.5	M10 x 1.0	2.2
	HPC25S 105A *	14940	25	105	90	70	61.3	52	17	10.5	M18 x 1.0	2.5
	HPC32S 120A *	15028	32	120	100	78	68.6	58	19	11.5	M18 x 1.0	3.6
Max. 8,000 min ⁻¹												
BTF50	HPC16 105A	15198	16	105	85	56	45.9	34	16	10	M10 x 1.0	4.4
	HPC16 150A	15680		150								5.1
	HPC20 105A	15150	20	105	100	62	53.3	44	17	10.5	M18 x 1.0	4.3
	HPC25 105A	15154										25
	HPC32 105A	15160	32	110	70	61.3	52	62	20	10.5	M18 x 1.0	4.4
	HPC42 110A	15166										42
	HPC16S 105A *	15167	16	105	85	62	53.3	44	17	10.5	M10 x 1.0	4.7
	HPC20S 105A *	15168	20	135	85	62	53.3	44	17	10.5	M10 x 1.0	4.6
	HPC20S 135A *	15170										165
	HPC20S 165A *	15172	25	165	100	70	61.3	52	19	11.5	M18 x 1.0	5.9
	HPC25S 105A *	15174										105
	HPC25S 135A *	15176	32	135	117	78	68.6	58	22	12.5	M18 x 1.0	5.4
	HPC25S 165A *	15178										165
	HPC32S 115A *	15180	32	200	110	92	84.1	72	22	12.5	M18 x 1.0	5.6
	HPC32S 135A *	15182										115
	HPC32S 165A *	15186	42	135	122	92	84.1	72	22	12.5	M18 x 1.0	7.7
	HPC32S 200A *	15187										165
	HPC42S 120A *	15188	50	135	120	100	92.5	78	29	13	-	6.3
	HPC42S 135A *	15190										165
	HPC42S 165A *	15192	50	135	120	100	92.5	78	29	13	-	8.3
	HPC50S 135A *	15193										165

*印は重切削用のスーパーマイクロチャックです。 * Marks : "Super MICRON CHUCK" for heavy cutting use.

- 注:1. ストレートコレットは141頁、チャックレンチは142頁、調整ネジは142頁をご覧ください。(別途ご注文下さい。)
2. 調整ネジのランニング切替中につき、在庫品には旧タイプ(ネジ無し)品もあります。
3. 表記の許容回転数は、機械の剛性と刃物のバランスに大きく左右されますので、表記中の回転数と異なる場合があります。

- NOTE:1. Please refer to P.141 for collets and P.142 for chuck wrench and P.142 for adjust screw. (Sold separately.)
2. Former version of Micron Chucks do not have the thread for the adjust screw.
3. The above-mentioned maximum speed will vary depending rigidity of the machine and balance of cutter. An adequate cutting condition should be selected for each case.

BTF30-HPC16-100A	ご注文例 Ordering Example
等級	Grade
GL長さ	G.L. Length
刃径	Cutter's Shank Dia.
呼称	Holder's Name
シャンクサイズ	Shank Size