

[アンギュラ型]

[Angular Type]

HSKA[Ⓝ]-FIC[Ⓧ]MIN AN-L-S

SHOWA TOOL CO., LTD.

1目盛り0.002 (mm/φ) で補正作業が思いのまま!!
Easy adjustment in φ0.002mm increments!!

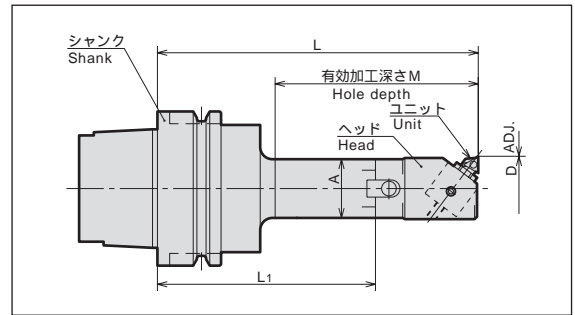

CODE			シャック SHANK	ヘッド HEAD	ユニット UNIT	加工径(D) RANGE	微調整量 ADJUST.	L	M	L1	A	N/W (kg)	PRICE (Yen)					
HSKA63	FIC 27AN 120 S	320065	SBS1 120	FCH27AN	FIC0AN	27 ~ 31	0.16	120	85	83	24	1.2	76,640					
	FIC 30AN 120 S	320066		FCH30AN		30 ~ 34						1.3						
	FIC 33AN 135 S	320067		FCH33AN		33 ~ 37						1.5						
	FIC 36AN 135 S	320068		FCH36AN	36 ~ 47	1.5												
	FIC 44AN 135 S	320069		FCH44AN	44 ~ 59	2.1												
	FIC 56AN 135 S	320070		FCH56AN	56 ~ 72	2.8												
	HSKA100	FIC 27AN 150 S	350080	SBS1 150	FCH27AN	FIC0AN	27 ~ 31	0.16	150	104	113	24	3.0	87,130				
		FIC 30AN 150 S	350081		FCH30AN		30 ~ 34						3.1					
		FIC 33AN 165 S	350082		FCH33AN		33 ~ 37						3.5					
		FIC 36AN 165 S	350083		FCH36AN	36 ~ 47	3.5											
		FIC 44AN 165 S	350084		FCH44AN	44 ~ 59	4.1											
		FIC 44AN 225 S	350085		FCH44AN	44 ~ 59	4.7											
HSKA100		FIC 56AN 165 S	350086	SBS4 165	FCH56AN	FIC3AN	56 ~ 72	0.32	165	119	112	54	5.0	107,950				
		FIC 56AN 240 S	350087		FCH56AN		56 ~ 72						6.3					
		FIC 56AN 285 S	350088		FCH56AN		56 ~ 72						7.1					
		FIC 69AN 165 S	350089		FCH69AN		69 ~ 85						5.9					
		FIC 69AN 240 S	350090		FCH69AN		69 ~ 85						7.8					
		FIC 69AN 330 S	350091		FCH69AN		69 ~ 85						10.1					
	HSKA100	FIC 82AN 165 S	350092	SBS5 165	FCH82AN	FIC3AN	82 ~ 98		0.32	165	119	100	64	6.4	124,480			
		FIC 82AN 240 S	350093		FCH82AN		82 ~ 98							8.3				
		FIC 82AN 330 S	350094		FCH82AN		82 ~ 98							10.6				
		FIC 95AN 190 S	350095		FCH95AN		95 ~ 111							9.4				
		FIC 95AN 245 S	350096		FCH95AN		95 ~ 111							11.8				
		FIC 95AN 335 S	350097		FCH95AN		95 ~ 111							15.5				
		HSKA100	FIC108AN 195 S	350098	SBS6 185	FCH108AN	FIC3AN			108 ~ 124	0.32	200	154	113	82	10.5	128,420	
			FIC108AN 250 S	350099		FCH108AN				108 ~ 124						12.9		
			FIC108AN 340 S	350100		FCH108AN				108 ~ 124						16.6		
			FIC121AN 200 S	350101		FCH121AN				121 ~ 137						12.0		
			FIC121AN 255 S	350102		FCH121AN				121 ~ 137						14.5		
			FIC121AN 345 S	350103		FCH121AN				121 ~ 137						18.1		
	HSKA100		FIC134AN 205 S	350104	SBS6 185	FCH134AN	FIC3AN			134 ~ 150		0.32	205	159	113	82	13.8	128,420
			FIC134AN 260 S	350105		FCH134AN				134 ~ 150							16.3	
			FIC134AN 350 S	350106		FCH134AN				134 ~ 150							19.9	
			FIC147AN 210 S	350107		FCH147AN				147 ~ 163							16.0	
			FIC147AN 265 S	350108		FCH147AN				147 ~ 163							18.5	
			FIC147AN 355 S	350109		FCH147AN				147 ~ 163							22.1	
HSKA100		FIC160AN 215 S	350110	SBS6 185	FCH160AN	FIC3AN	160 ~ 176	0.32		215			169	113	82	18.5	143,720	
		FIC160AN 270 S	350111		FCH160AN		160 ~ 176									21.0		
		FIC160AN 360 S	350112		FCH160AN		160 ~ 176									24.6		

- 1.クーラントパイプは付属しております。
- 2.チップは付属していません。別途お求め下さい。→P.93
- 3.刃先とドライブキーは同位相です。
- 4.特殊品も製作致します。
- 5.切削条件については、13頁をご覧ください。
- 6.アクセサリは143頁をご覧ください。

- 1.Coolant pipe is included.
- 2.Inserts are sold separately. Please refer to P.93
- 3.Inserts are in phase with the drive key.
- 4.Specials are manufactured to orders.
- 5.Please refer to P.13 for cutting conditions.
- 6.Please refer to P.143 for accessory.

HSKA63-FIC 27 AN-120 S ご注文例 Ordering Example

Set
GL長さ L G.L. Length
アンギュラ型 Angular Type
Min. φD
呼称 Name
シャックサイズ Shank Size