

# マイクロチャック Mシリーズ (モールドチャック)

MICRON CHUCK M series (Mold Chuck)  
SHOWA TOOL CO., LTD.

BT (No.) -HPC (D) M - (L)

センタースルー対応可能  
Thru-the-tool Coolant Available

P. 4



注: h6公差エンドミルシャック専用  
(ドリル、タップは使用出来ません)

NOTE: Endmill only which has h6  
or closer shank.  
(Please don't use for  
drilling or tapping)

Hシリーズを、さらにスリム・ロング化! 金型深堀り加工に最適。  
Slim and extended 'H' series MICRON CHUCK for cutting deep die molds.

## 特長 Features

- 干渉の少ないスリムな形状
- 高精度・高バランスで高速加工に対応
- 簡単なチャッキングにより作業効率向上
- Slim - Reachable to deep places.
- High accuracy and balanced-good for high speed cutting.
- Easy mechanical chucking.

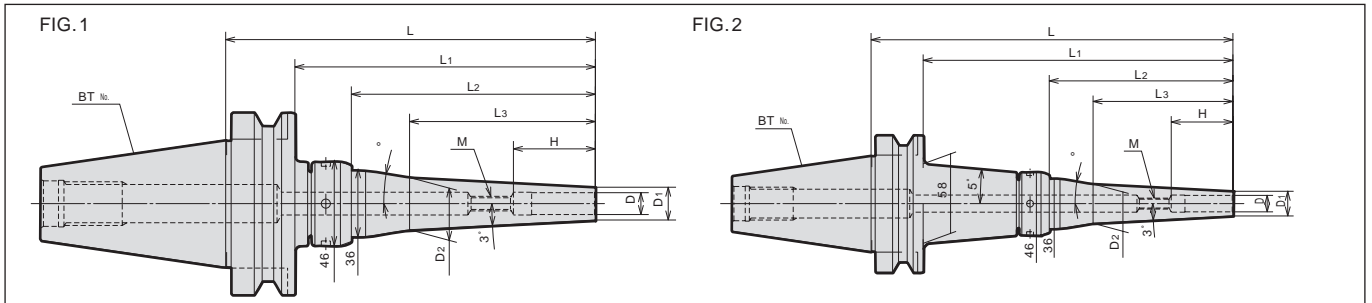

CODE	FIG.	D	D1	D2	L	L1	L2	L3	H	°	M	N/W (kg)	PRICE (Yen)		
Max. 15,000 min <sup>-1</sup>															
BT40	-HPC03M-135	220110	3	9	16	135	108	84	67	18	34	-	1.4	55,300	
	-HPC03M-185	220116			20	185	158	134	102		18		1.6	60,800	
	-HPC04M-135	220111	4	10	17	135	108	84	67	20	33	-	1.4	55,300	
	-HPC04M-185	220117			21	185	158	134	102		17		1.6	60,800	
	-HPC06M-135	220112	6	12	19	135	108	84	67	36	30	-	1.5	55,300	
	-HPC06M-185	220118			23	185	158	134	102		15		1.6	60,800	
	-HPC08M-135	220113	8	14	21	135	108	84	67	50	27	M6	1.5	55,300	
	-HPC08M-185	220119			25	185	158	134	102		13		1.7	60,800	
	-HPC10M-135	220114	10	16	23	135	108	84	67		24	M8	1.5	55,300	
	-HPC10M-185	220120			27	185	158	134	102		11		1.7	60,800	
	-HPC12M-135	220115	12	18	25	135	108	84	67	55	21	M10	1.5	55,300	
	-HPC12M-185	220121			29	185	158	134	102		9		1.7	60,800	
Max. 10,000 min <sup>-1</sup>															
BT50	-HPC03M-150	250200	1	3	9	16	150	112	84	67	18	34	-	4.2	65,500
	-HPC03M-200	250206				20	200	162	134	102		18		4.4	72,000
	-HPC03M-250	250212	2			20	250	212	134	102	18		5.3	79,200	
	-HPC04M-150	250201	1	4	10	17	150	112	84	67	20	33	-	4.3	65,500
	-HPC04M-200	250207				21	200	162	134	102		17		4.4	72,000
	-HPC04M-250	250213	2			21	250	212	134	102	17		5.3	79,200	
	-HPC06M-150	250202	1	6	12	19	150	112	84	67	36	30	-	4.3	65,500
	-HPC06M-200	250208				23	200	162	134	102		15		4.5	72,000
	-HPC06M-250	250214	2			23	250	212	134	102	15		5.3	79,200	
	-HPC08M-150	250203	1	8	14	21	150	112	84	67	50	27	M6	4.3	65,500
	-HPC08M-200	250209				25	200	162	134	102		13		4.5	72,000
	-HPC08M-250	250215	2			25	250	212	134	102		13		5.4	79,200
	-HPC10M-150	250204	1	10	16	23	150	112	84	67		24	M8	4.3	65,500
	-HPC10M-200	250210				27	200	162	134	102	11	4.5		72,000	
	-HPC10M-250	250216	2			27	250	212	134	102	11		5.4	79,200	
	-HPC12M-150	250205	1	12	18	25	150	112	84	67	55	21	M10	4.3	65,500
	-HPC12M-200	250211				29	200	162	134	102		9		4.5	72,000
	-HPC12M-250	250217	2			29	250	212	134	102	9		5.4	79,200	

注:1. チャックレンチは、142頁をご覧ください。(別途ご注文下さい。)  
2. 調整ネジのランニンググ切替中につき、在庫品には旧タイプ(ネジ無し)品もあります。  
3. 調整ネジは受注生産致します。  
4. 表記の許容回転数は、機械の剛性と刃物のバランスに大きく左右されますので、表記中の回転数と異なる場合があります。

NOTE:1. Please refer to P.142 for chuck wrench. (Sold separately.)  
2. Former version of "M" series Micron Chucks do not have the thread for the adjust screw.  
3. Adjust Screws are manufactured to order.  
4. The above-mentioned maximum speed will vary depending rigidity of the machine and balance of cutter. An adequate cutting condition should be selected for each case.

BT50-HPC06M-150 注文例 Ordering Example

GL長さ L G.L. Length  
Mシリーズ M series  
刃具シャック径 φD Cutter's Shank Dia.  
呼称 Holder's Name  
シャックサイズ Shank Size